

INTELLIGENT
ALUMINIUM
SECTIONS

FOR
WINDOWS
GATE
RAILING
SLIM
DOMAL
CASEMENT
CURTAIN WALL



INTELLIGENT
ALUMINIUM

itswallpanel.com

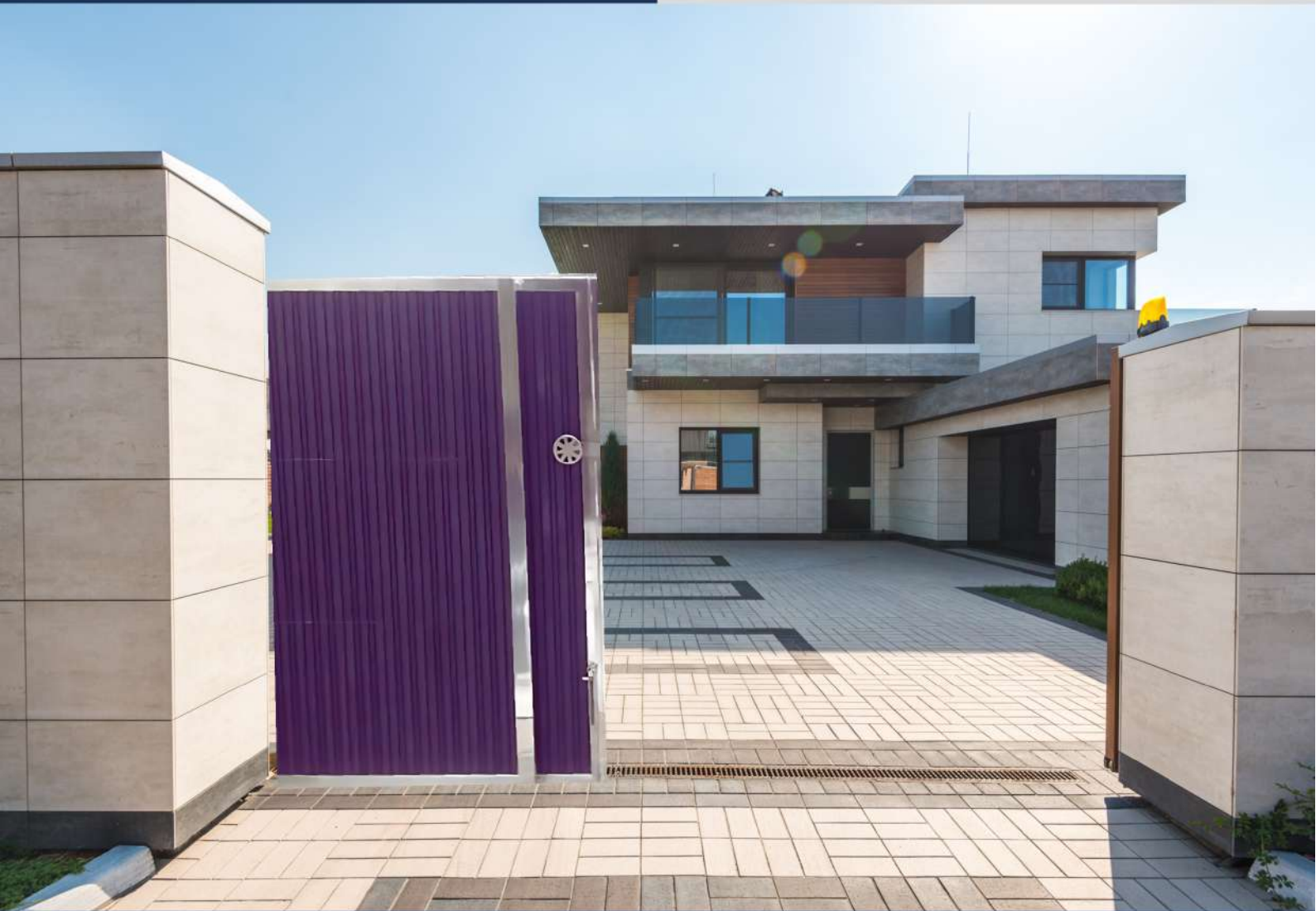

Intelligent Aluminium

2024

GATE PROFILE



INTELLIGENT
ALUMINIUM
itowalpanel.com

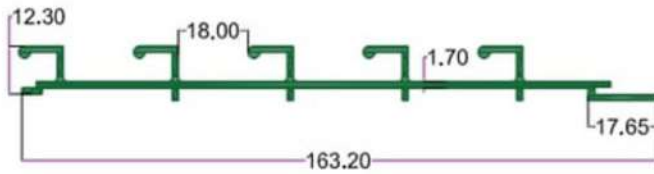

SEC. NO. 4130
WT. 4.600 TO 4.850 KG./12'

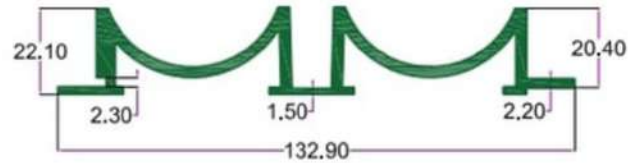

SEC. NO. 4096
WT. 6.450 TO 6.750 KG./12'

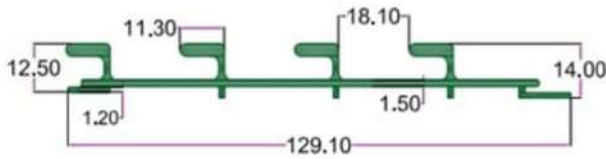

SEC. NO. 4093
WT. 4.000 TO 4.500 KG./12'



SEC. NO. 4095
WT. 2.950 TO 3.250 KG./12'

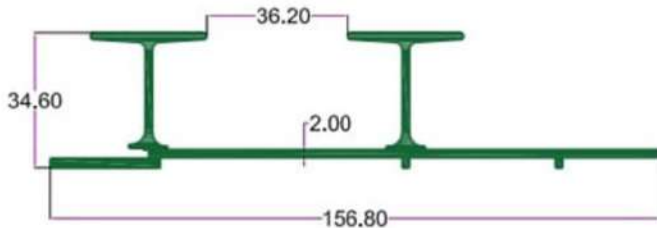

SEC. NO. 4098
WT. 5.900 TO 6.200 KG./ 12'

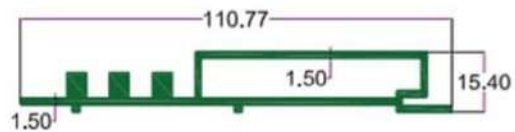

SEC. NO. 4479
WT. 4.040 TO 4.250 KG/ 12'

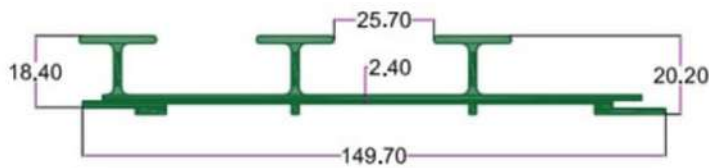

SEC. NO. 4094
WT. 5.900 TO 6.300 KG./ 12'

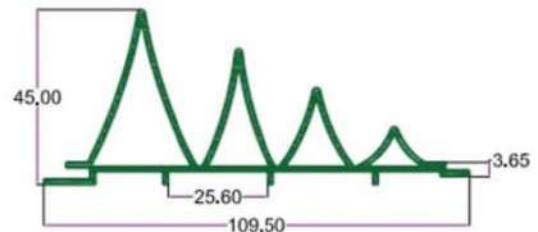

SEC. NO. 4549
WT. 4.800 TO 5.000 KG./ 12'

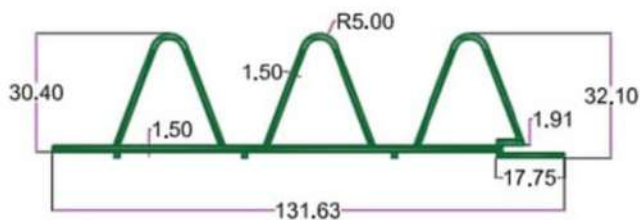

SEC. NO. 4356
WT. 5.000 TO 5.350 KG./ 12'

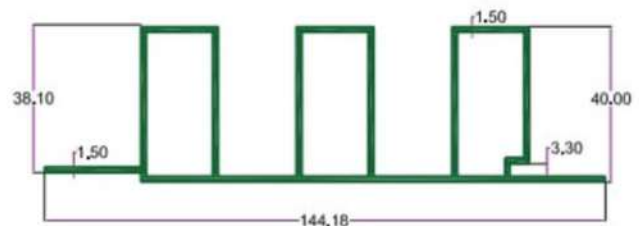

SEC. NO. 4542
WT. 6.390 TO 6.550 KG./ 12'

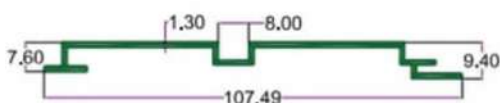

SEC. NO. 4650
WT. 1.800 TO 2.000 KG./ 12'

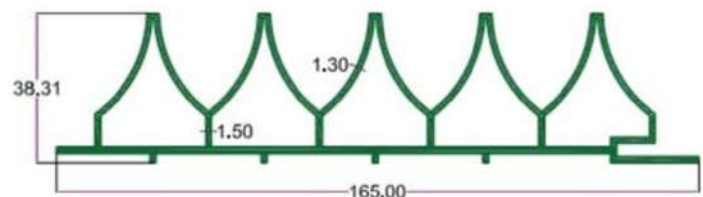

SEC. NO. 4968
WT. 7.400 TO 7.700 KG/12'

GATE PROFILE



INTELLIGENT
ALUMINIUM
itowalpanel.com

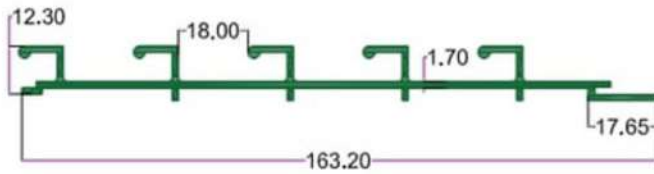

SEC. NO. 4130
WT. 4.600 TO 4.850 KG./12'

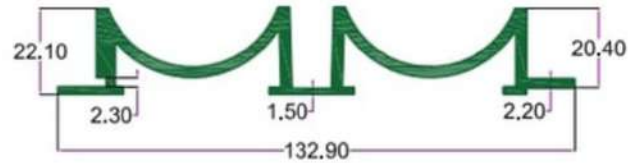

SEC. NO. 4096
WT. 6.450 TO 6.750 KG./12'

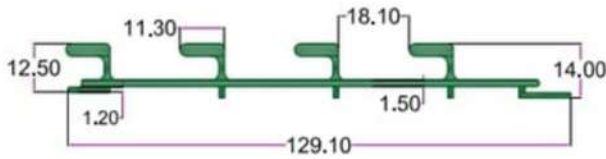

SEC. NO. 4093
WT. 4.000 TO 4.500 KG./12'



SEC. NO. 4095
WT. 2.950 TO 3.250 KG./12'

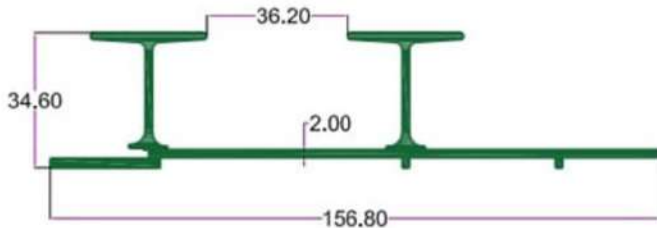

SEC. NO. 4098
WT. 5.900 TO 6.200 KG./ 12'

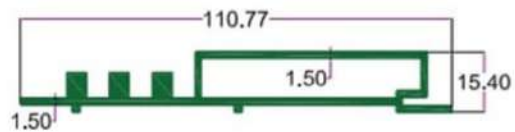

SEC. NO. 4479
WT. 4.040 TO 4.250 KG/ 12'

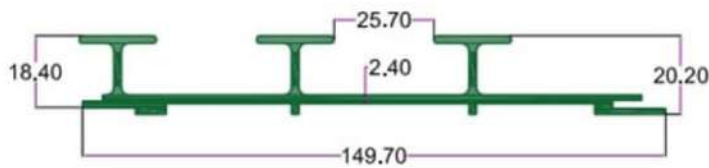

SEC. NO. 4094
WT. 5.900 TO 6.300 KG./ 12'

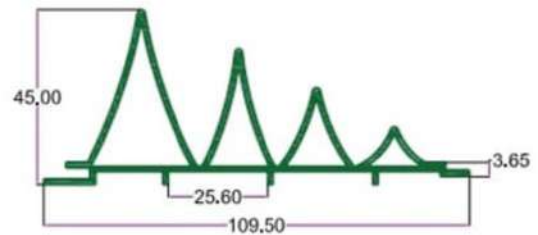

SEC. NO. 4549
WT. 4.800 TO 5.000 KG./ 12'

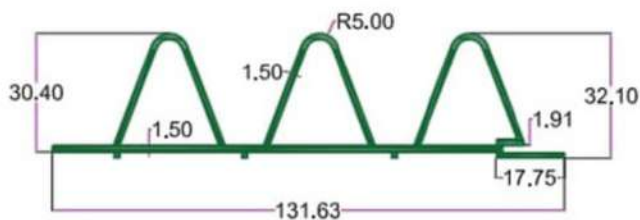

SEC. NO. 4356
WT. 5.000 TO 5.350 KG./ 12'

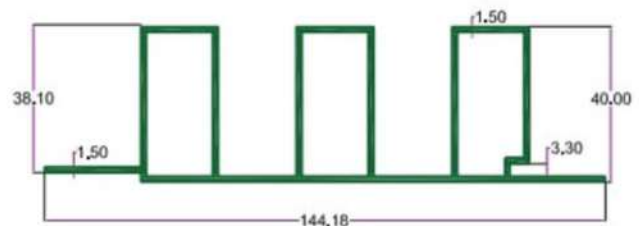

SEC. NO. 4542
WT. 6.390 TO 6.550 KG./ 12'

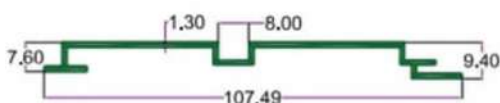

SEC. NO. 4650
WT. 1.800 TO 2.000 KG./ 12'

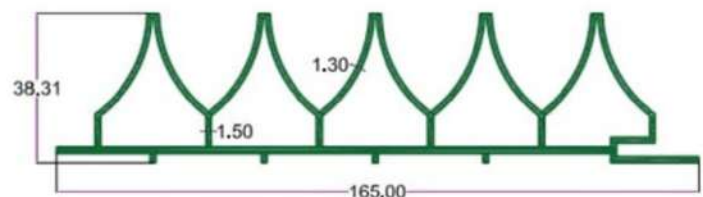

SEC. NO. 4968
WT. 7.400 TO 7.700 KG/12'

GATE PROFILE



INTELLIGENT
ALUMINIUM
itowalpanel.com

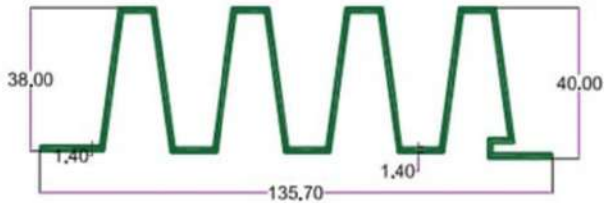

SEC.NO. 4550
WT. 5.660 TO 5.850 KG./ 12'

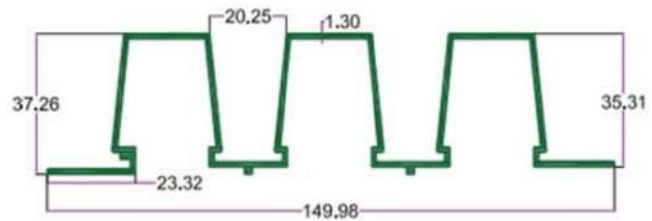

SEC.NO. 4627
WT. 4.850 TO 5.000 KG./ 12'

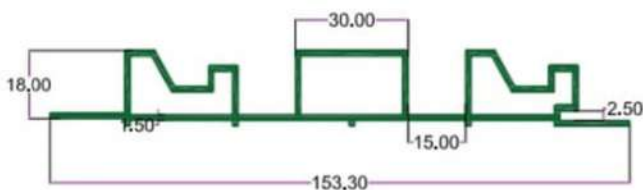

SEC.NO. 4871
WT. 5.380 TO 5.580 KG./ 12'

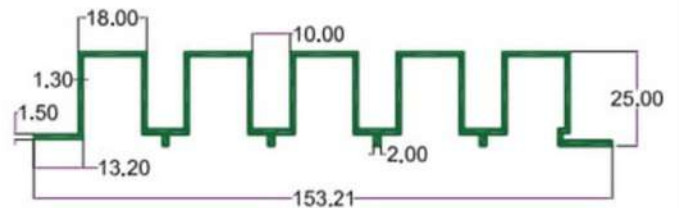

SEC.NO. 4355
WT. 5.130 TO 5.350 KG./ 12'

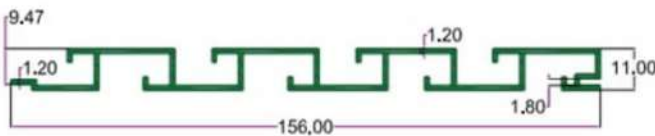

SEC.NO. 4458
WT. 3.750 TO 3.950 KG./ 12'

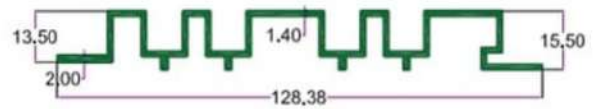

SEC.NO. 4547
WT. 3.780 TO 3.900 KG./ 12'

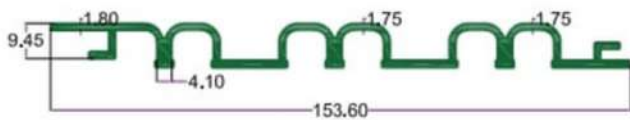

SEC.NO. 4897
WT. 4.825 TO 5.125 KG./ 12'

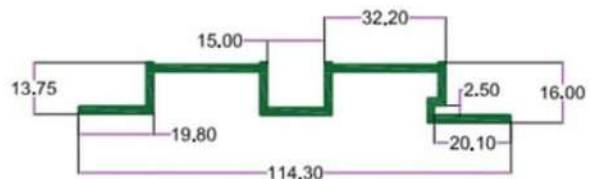

SEC.NO. 4291
WT. 3.350 TO 3.600 KG./ 12'



SEC. NO. 4183
WT. 3.650 TO 3.850 KG./ 12'

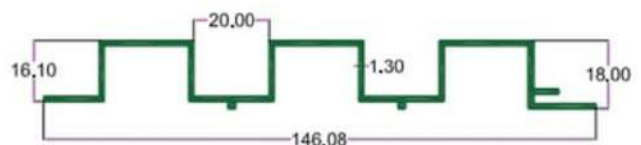

SEC.NO. 4723
WT. 3.220 TO 3.400 KG./ 12'



SEC.NO. 4575
WT. 2.690 TO 2.850 KG./ 12'

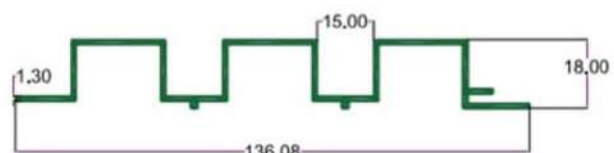

SEC.NO. 4693
WT. 3.100 TO 3.250 KG./ 12'

GATE PROFILE



INTELLIGENT
ALUMINIUM
itowalpanel.com

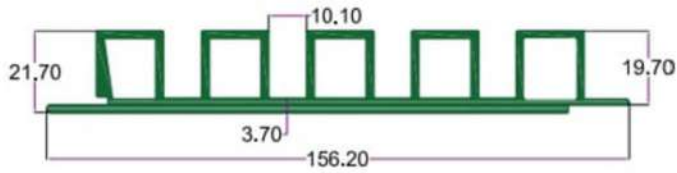

SEC. NO. 4097
WT. 10.100 TO 10.500 KG./12'

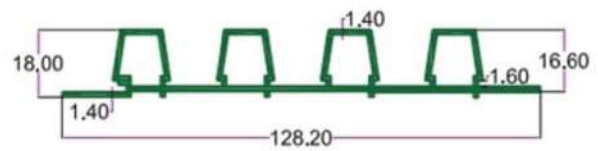

SEC. NO. 4126
WT. 4.150 TO 4.300 KG./12'

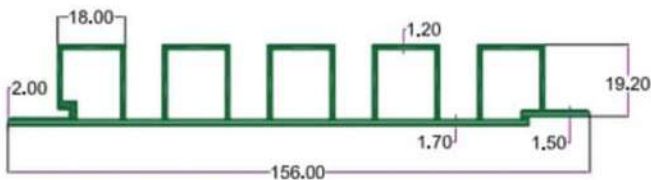

SEC. NO. 4512
WT. 6.050 TO 6.250 KG./ 12'

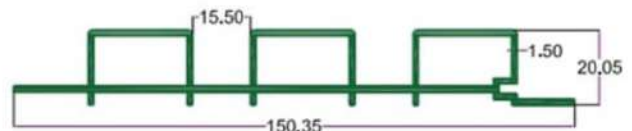

SEC. NO. 5127
WT. 5.200 TO 5.450 KG/12'

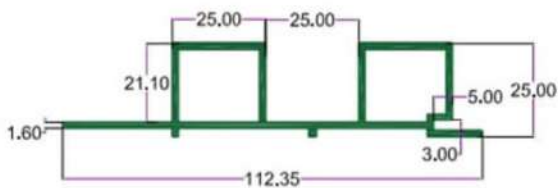

SEC. NO. 4801
WT. 4.000 TO 4.250 KG./ 12'

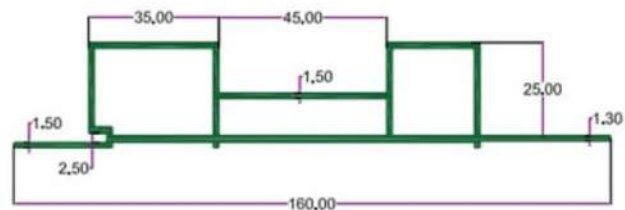

SEC. NO. 4805
WT. 5.400 TO 5.600 KG./ 12'

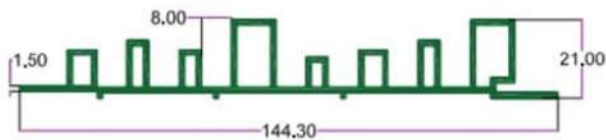

SEC. NO. 4872
WT. 5.820 TO 6.100 KG./ 12'

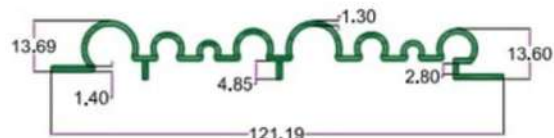

SEC. NO. 4541
WT. 3.080 TO 3.250 KG./12'



SEC. NO. 4786
WT. 3.650 TO 3.850 KG./ 12'

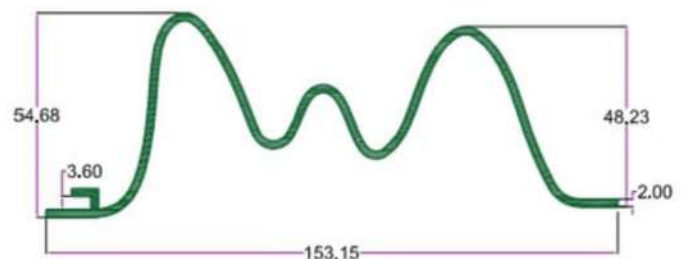

SEC. NO. 4532
WT. 5.670 TO 5.850 KG./ 12'

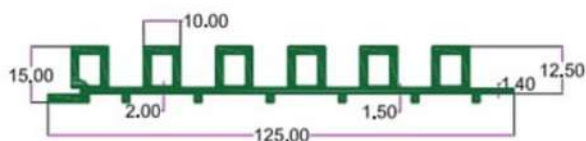

SEC. NO. 4378
WT. 5.780 TO 6.000 KG./12'

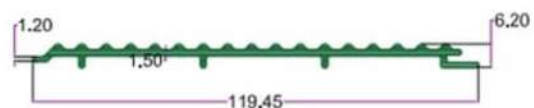

SEC. NO. 4837
WT. 2.620 TO 2.820 KG./ 12'

RAILING



INTELLIGENT
ALUMINIUM
itwalpanel.com

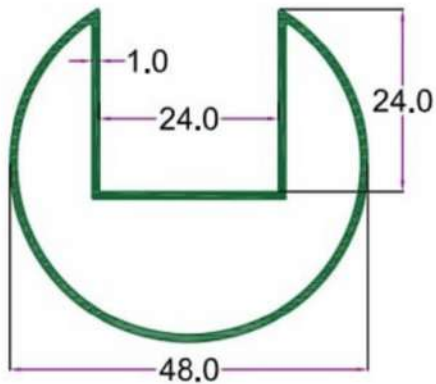

SEC. NO. 3539
WT. 1.800 TO 2.100 KG/12'

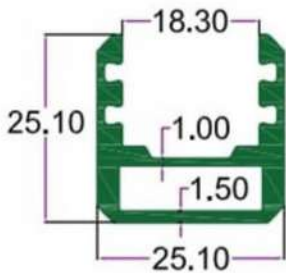

SEC. NO. 4332
WT. 1.850 TO 2.100 KG/12'

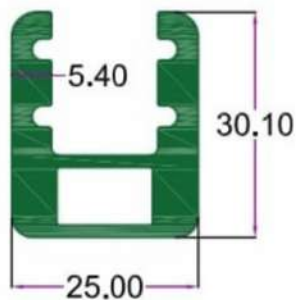

SEC. NO. 4087
WT. 3.450 TO 3.650 KG/12'

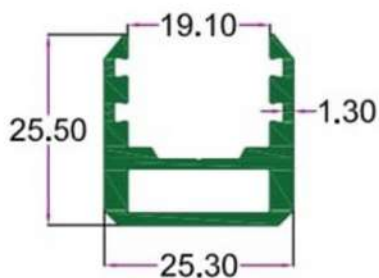

SEC. NO. 4408
WT. 1.900 TO 2.100 KG/12'

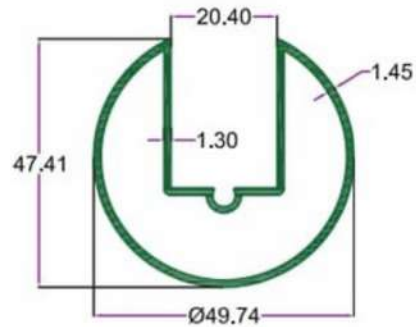

SEC. NO. 4349
WT. 2.820 TO 3.000 KG/12'

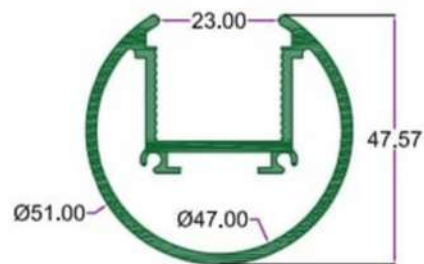

SEC. NO. 3498
WT. 4.180 TO 4.580 KG/12'

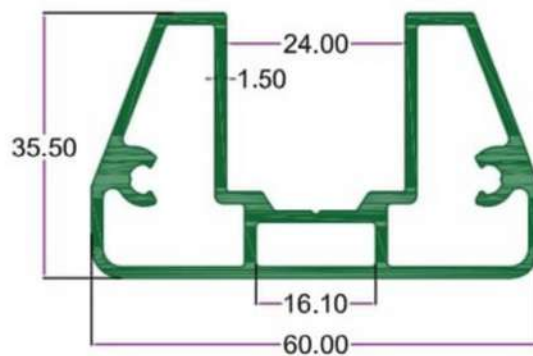

SEC. NO. 4863
WT. 4.130 TO 4.380 KG/12'

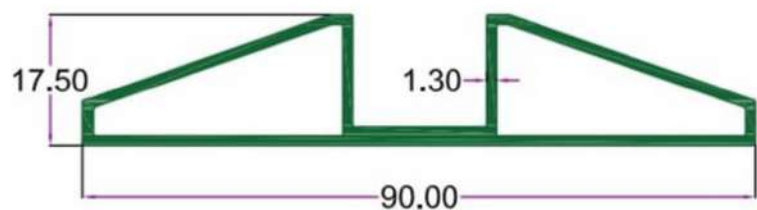

SEC. NO. 5143
WT. 2.820 TO 3.070 KG/12'

RAILING



INTELLIGENT
ALUMINIUM
itowalpanel.com

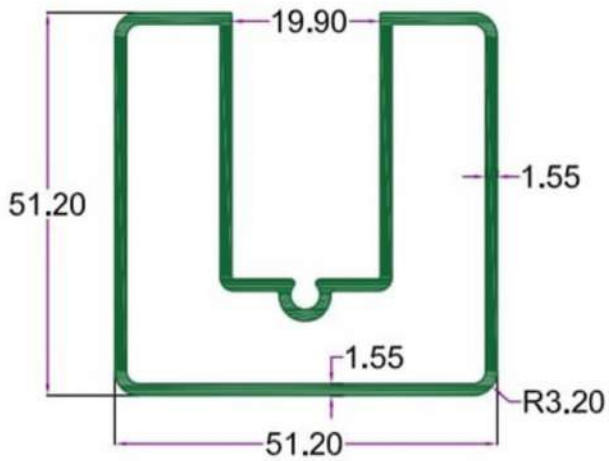

SEC.NO. 4369
WT. 4.120 TO 4.300 KG/12'

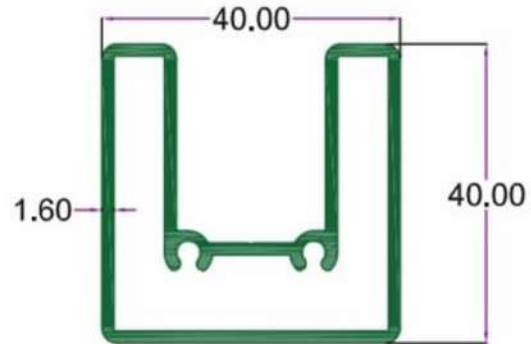

SEC. NO. 3923
WT. 3.300 TO 3.500 KG/12'

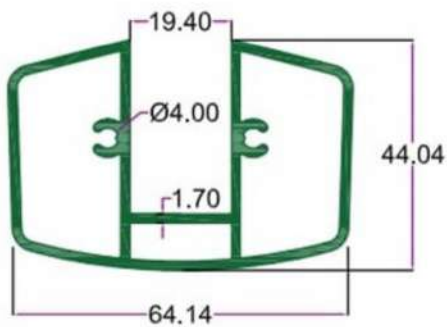

SEC.NO. 4642
WT. 4.940 TO 5.200 KG/12'

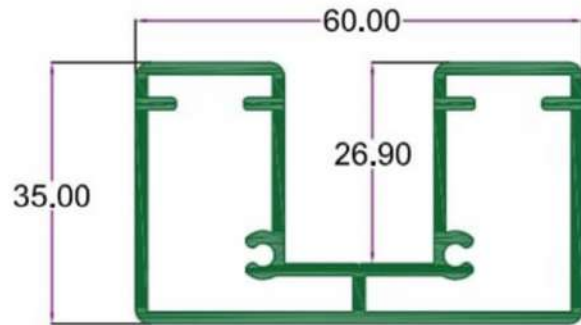

SEC. NO. 3925
WT. 4.200 TO 4.500 KG/12'

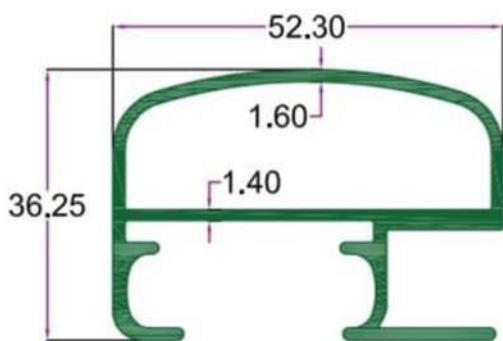

SEC.NO. 4336
WT. 3.200 TO 3.450 KG/12'

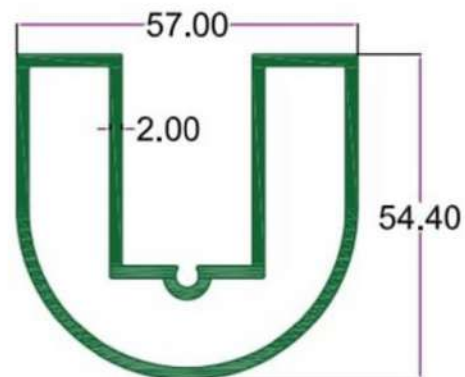

SEC.NO. 5178
WT. 5.270 TO 5.520 KG/12'

RAILING



INTELLIGENT
ALUMINIUM
itwalpanel.com

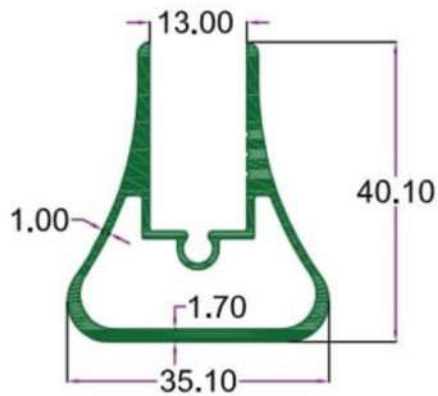

SEC.NO. 4330
WT. 2.200 TO 2.400 KG/12'

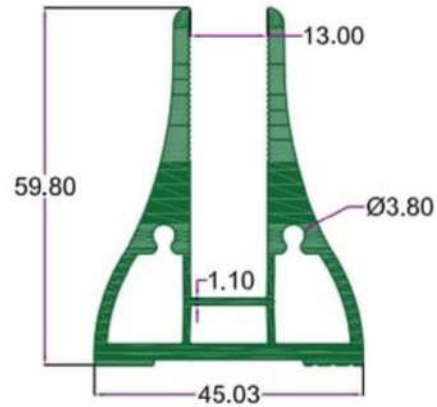

SEC.NO. 4331
WT. 5.950 TO 6.250 KG/12'

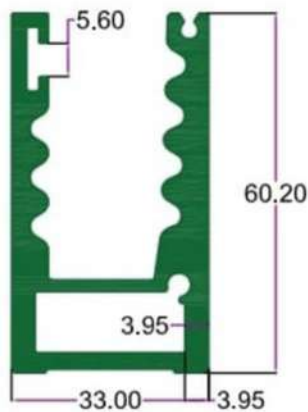

SEC.NO. 5112
WT. 7.080 TO 7.335 KG/12'

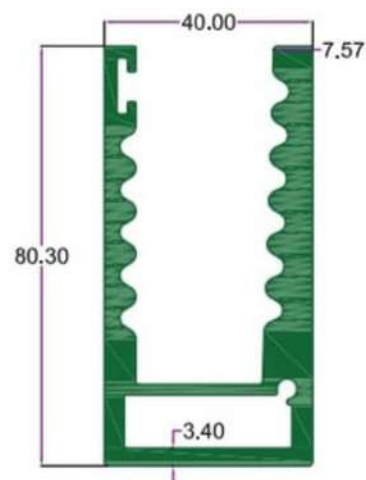

SEC.NO. 4607
WT. 10.530 TO 10.750 KG/12'

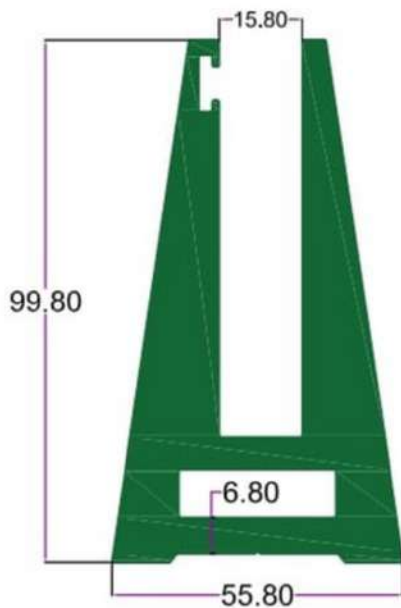

SEC.NO. 5197
WT. 25.000 TO 25.500 KG/12'

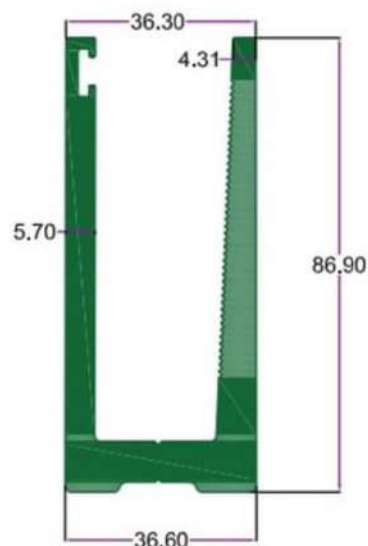

SEC.NO. 4339
WT. 11.700 TO 12.500 KG/12'

RAILING



INTELLIGENT
ALUMINIUM
itowalpanel.com

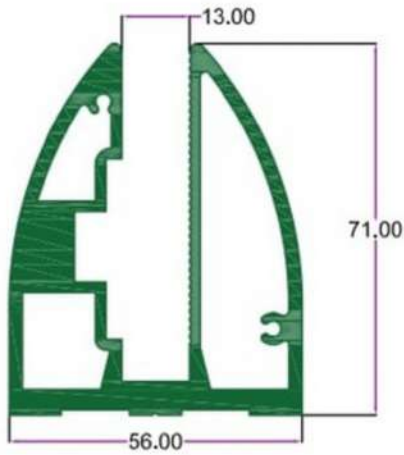

SEC. NO. 3497
WT. 10.700 TO 11.200 KG/12'

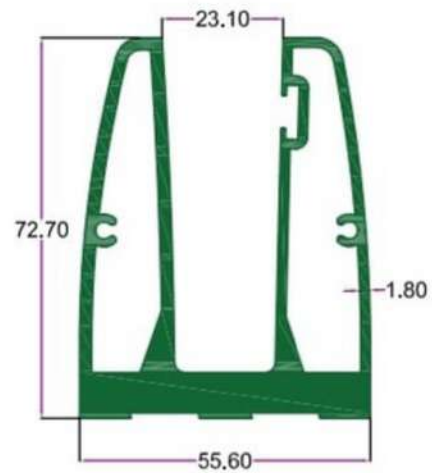

SEC. NO. 4088
WT. 10.750 TO 11.100 KG/12'

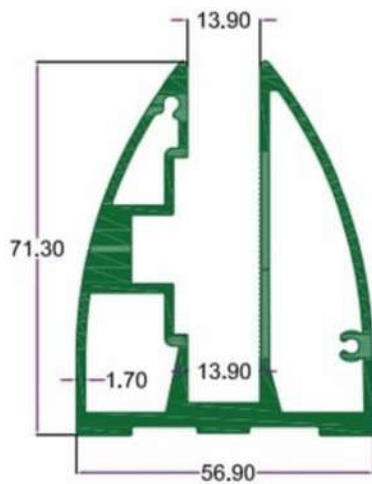

SEC. NO. 4395
WT. 8.300 TO 8.650 KG/12'

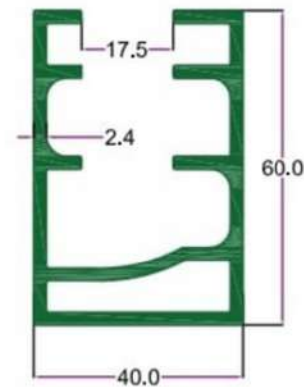

SEC. NO. 3535
WT. 5.600 TO 6.300 KG/12'

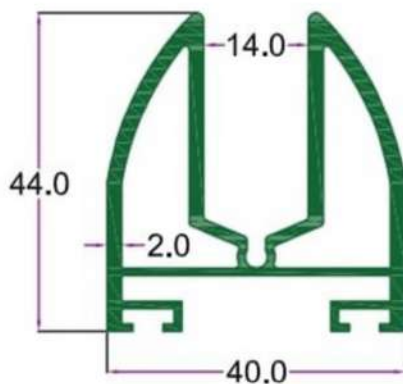

SEC. NO. 3536
WT. 3.650 TO 4.100 KG/12'

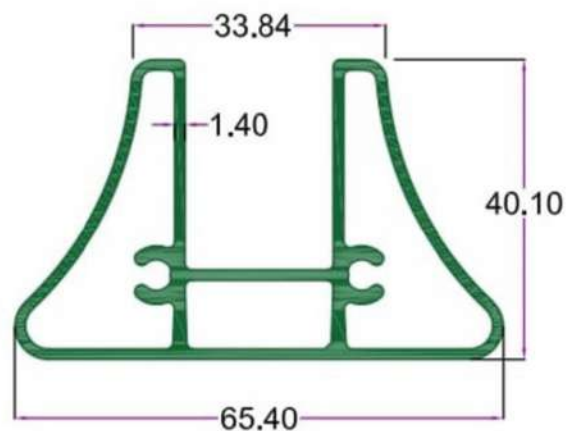

SEC. NO. 4337
WT. 4.100 TO 4.300 KG/12'

RAILING



INTELLIGENT
ALUMINIUM
itowalpanel.com

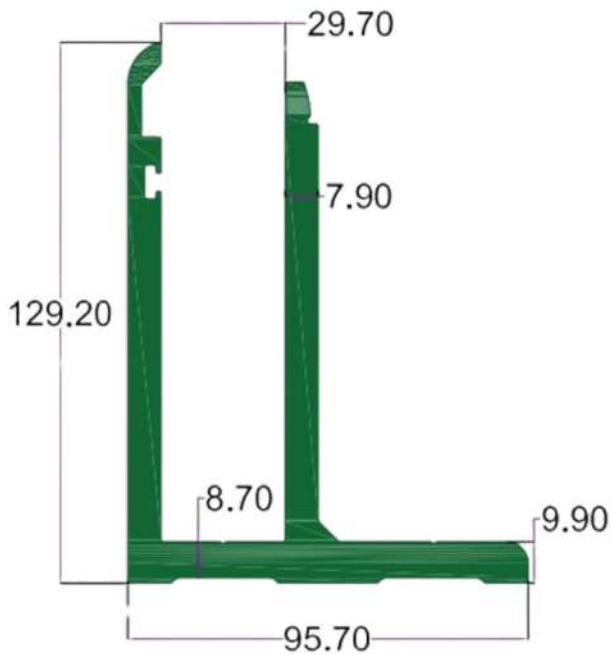

SEC.NO. 4681
WT. 25.300 TO 25.500 KG/12'



SEC.NO. 4338
WT. 19.300 TO 19.800 KG/12'

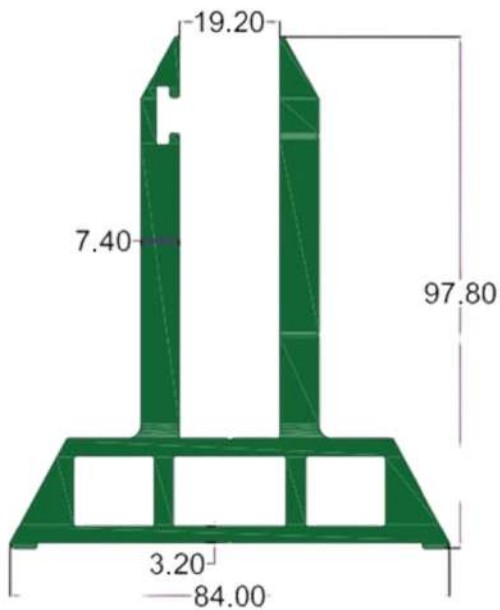

SEC.NO. 4714
WT. 17.600 TO 17.900 KG/12'

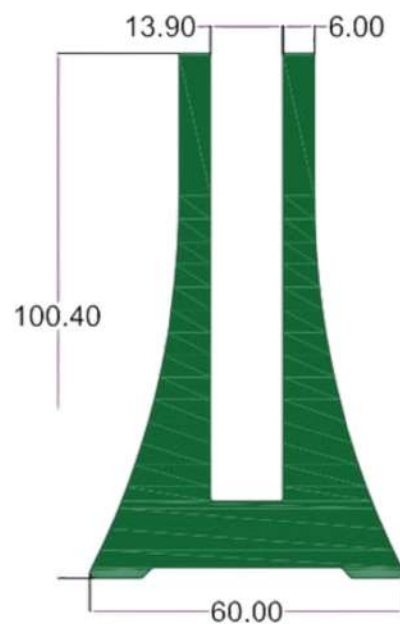

SEC.NO. 5198
WT. 21.450 TO 21.950 KG/12'

RAILING



INTELLIGENT
ALUMINIUM
itwalpanel.com

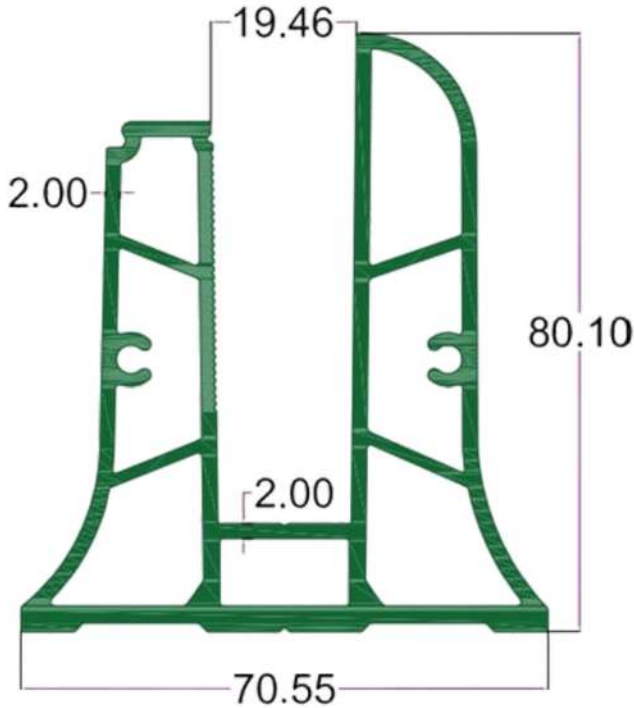

SEC.NO. 5179
WT. 9.560 TO 9.810 KG/12'

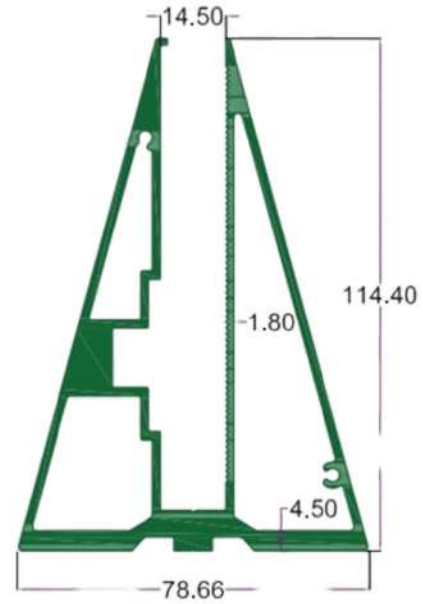

SEC.NO. 4606
WT. 12.870 TO 13.100 KG/12'

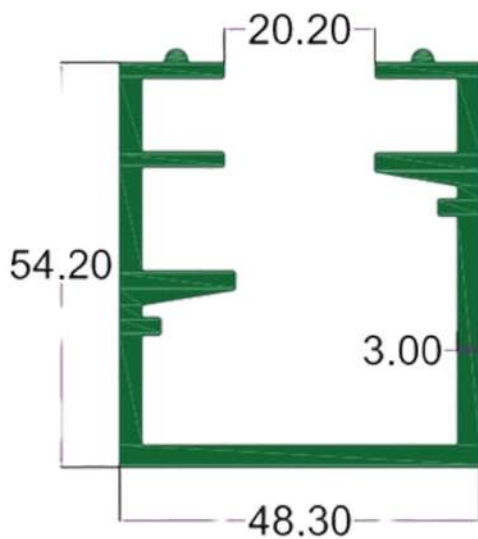

SEC.NO. 5110
WT. 6.165 TO 6.415 KG/12'

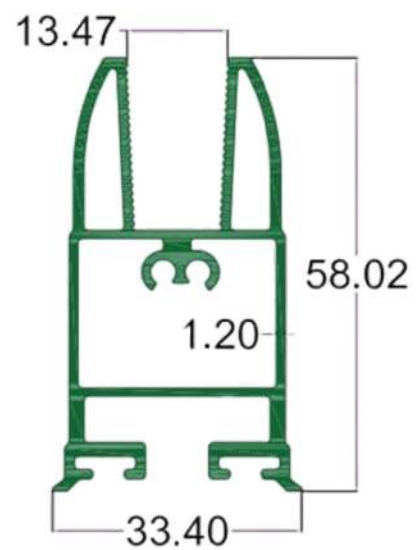

SEC.NO. 5111
WT. 3.648 TO 3.895 KG/12'

RAILING



INTELLIGENT
ALUMINIUM
itwalpanel.com

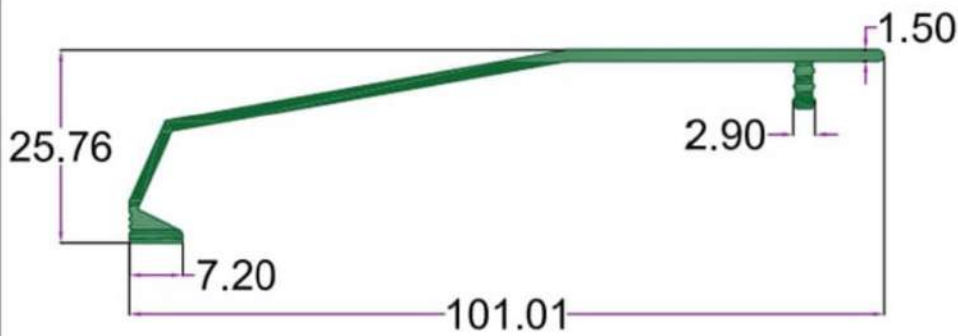

SEC. NO. 4273
WT. 1.950 TO 6.280 KG/I2'

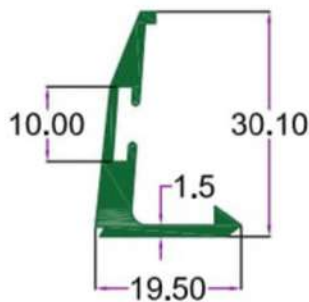

SEC. NO. 2884
WT. 1.100 TO 1.350 KG/I2'

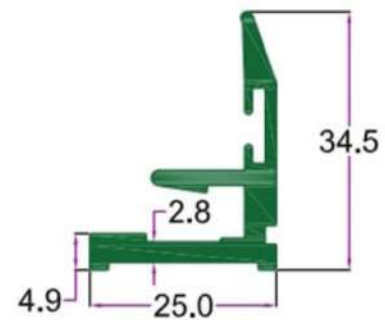

SEC. NO. 2885
WT. 2.000 TO 2.300 KG/I2'



SEC. NO. 3667
WT. 0.550 TO 0.600 KG/I2'

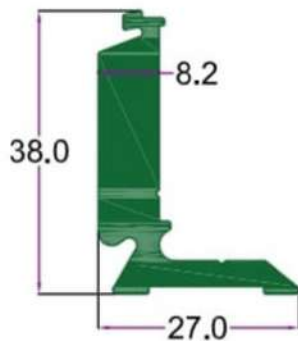

SEC. NO. 3666
WT. 3.200 TO 3.500 KG/I2'

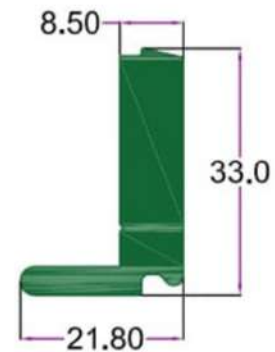

SEC. NO. 3665
WT. 3.075 TO 3.350 KG/I2'

RAILING



INTELLIGENT
ALUMINIUM
itwalpanel.com

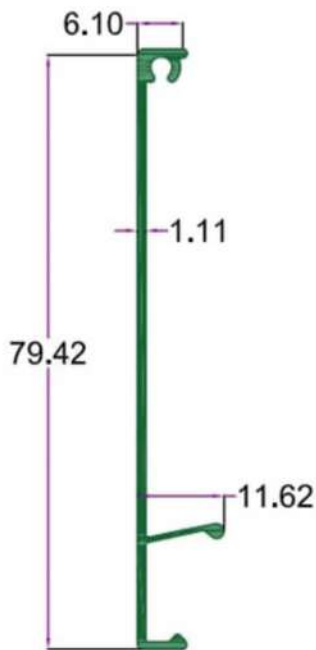

SEC.NO. 4668
WT. 1.150 TO 1.300 KG/12'

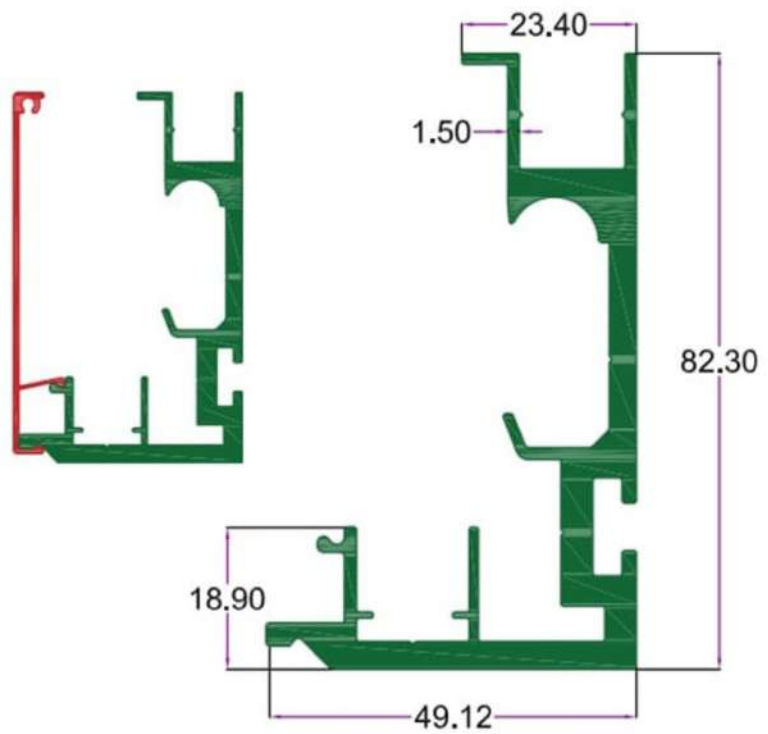

SEC.NO. 4667
WT. 6.800 TO 7.100 KG/12'

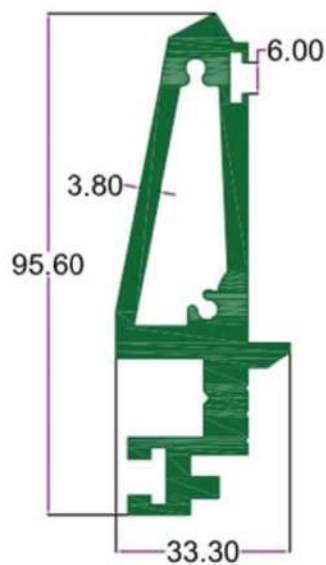

SEC.NO. 4274
WT. 10.050 TO 10.500 KG/12'



SEC.NO. 4275
WT. 14.800 TO 15.400 KG/12'



RAILING / CHANNEL

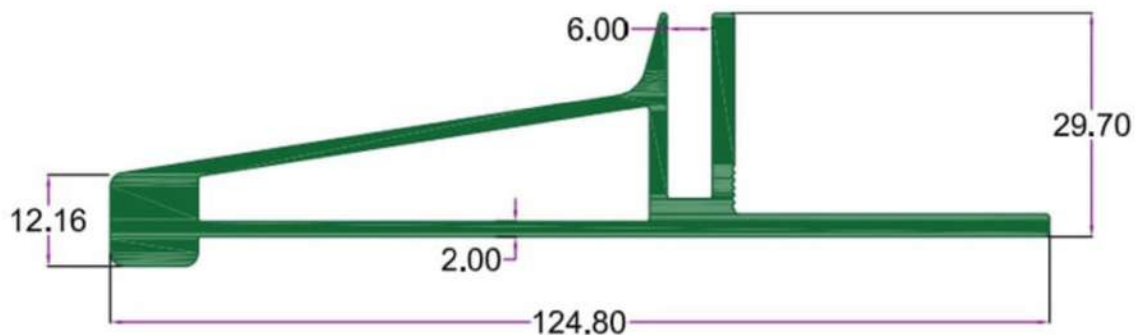
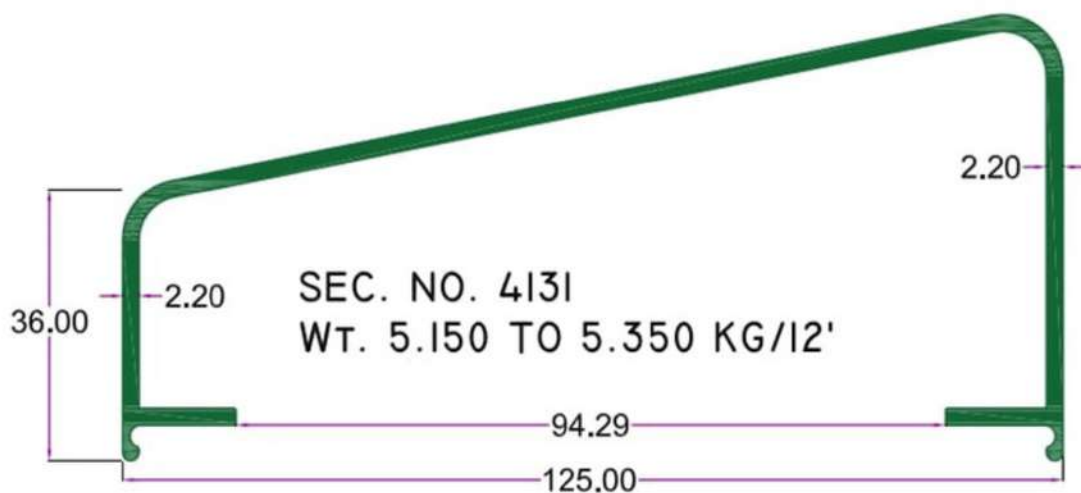
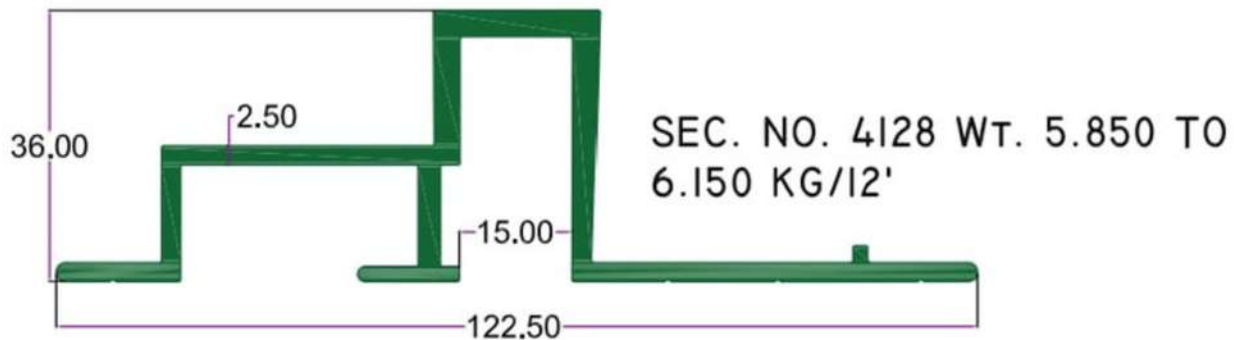

SEC. NO. 4335
WT. 6.960 TO 7.200 KG/12'

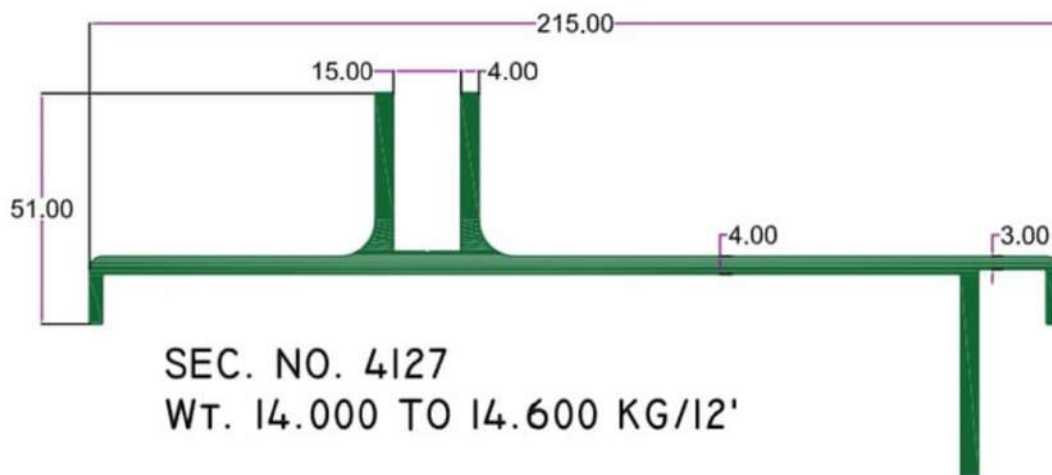

SEC. NO. 4127
WT. 14.000 TO 14.600 KG/12'

RAILING



INTELLIGENT
ALUMINIUM
itowalpanel.com

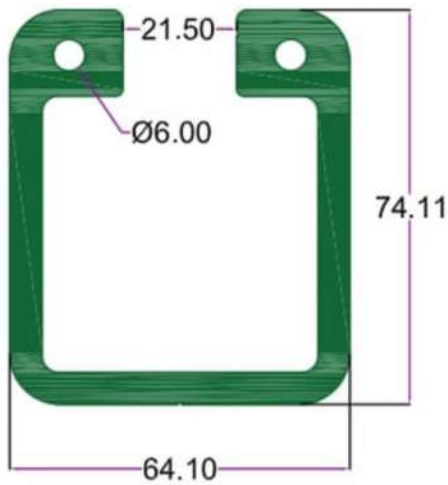

SEC.NO. 4399
WT. 15.600 TO 16.150 KG/12'

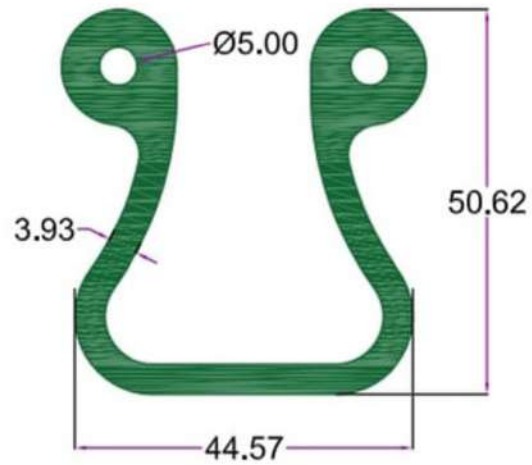

SEC.NO. 4702
WT. 7.570 TO 7.820 KG/12'

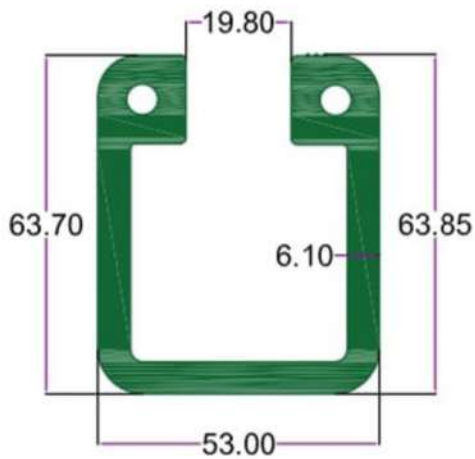

SEC.NO. 4763
WT. 12.500 TO 12.900 KG/12'

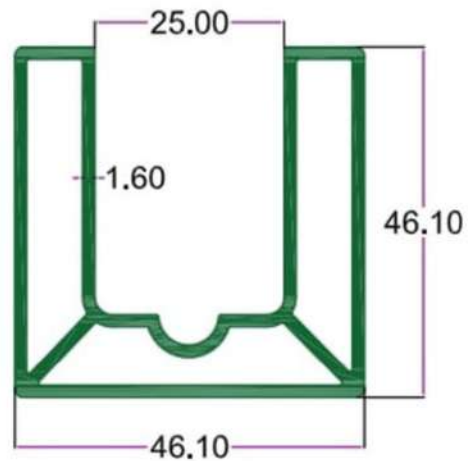

SEC.NO. 4604
WT. 4.400 TO 4.600 KG/12'

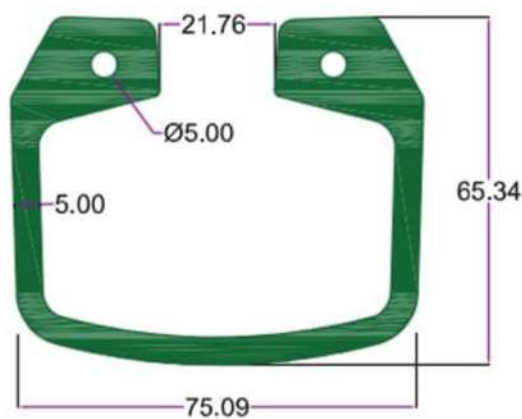

SEC.NO. 4641
WT. 15.250 TO 15.500 KG/12'

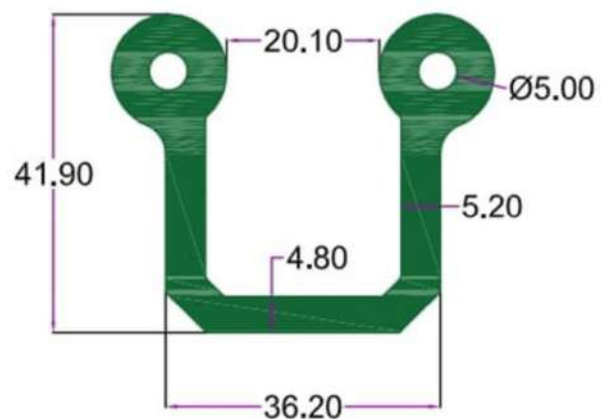

SEC.NO. 4407
WT. 7.000 TO 7.350 KG/12'



SLIM

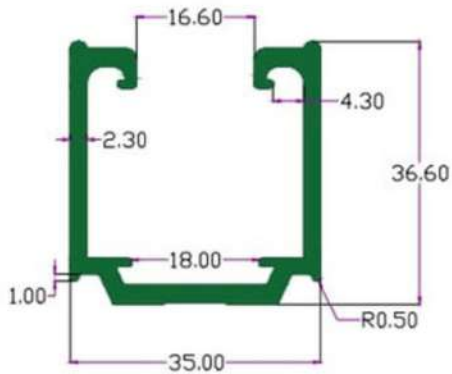

SEC.NO. 4363
Wt. 2.850 TO 3.000 KG./ 12'

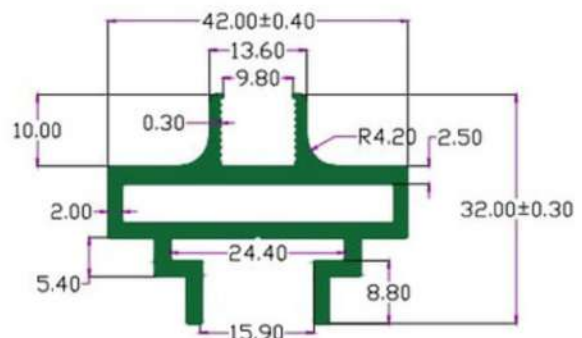

SEC.NO. 4364
Wt. 3.130 TO 3.350 KG./ 12'

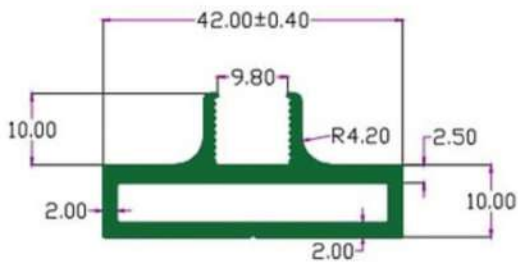

SEC.NO. 4365
Wt. 2.400 TO 2.650 KG./ 12'

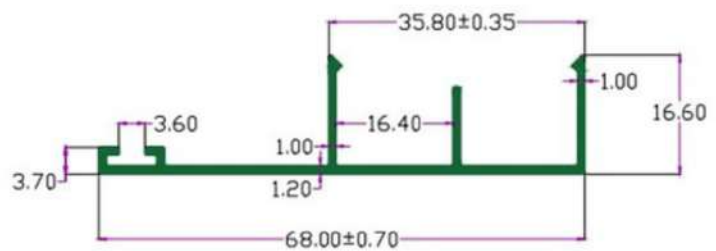

SEC.NO. 4366
Wt. 1.300 TO 1.450 KG./ 12'

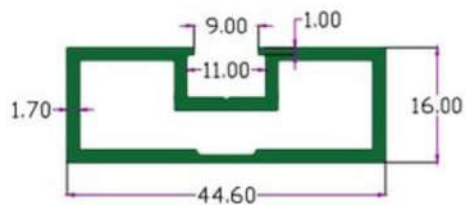

SEC.NO. 4429(K.I)
Wt. 2.120 TO 2.300 KG./ 12'

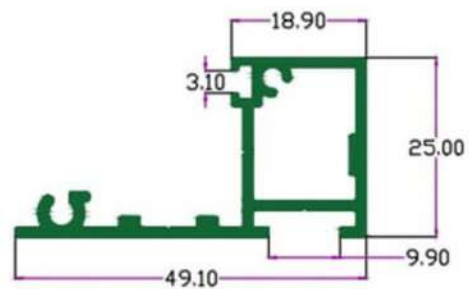

SEC.NO. 4467
Wt. 9.160 TO 9.350 KG./ 12'

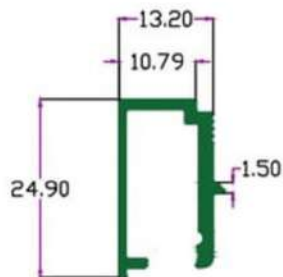

SEC.NO. 4468
Wt. 0.860 TO 0.100 KG./ 12'

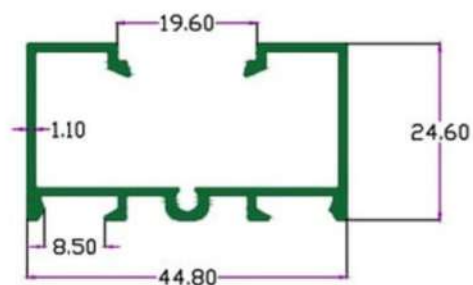

SEC.NO. 4508
Wt. 1.580 TO 1.700 KG./ 12'



SLIM

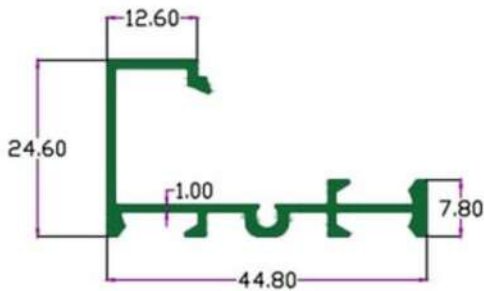

SEC.NO. 4509

Wt. 1.300 TO 1.500 KG./ 12'

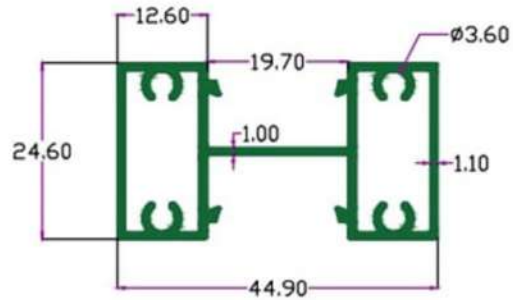

SEC.NO. 4510

Wt. 2.200 TO 2.450 KG./ 12'

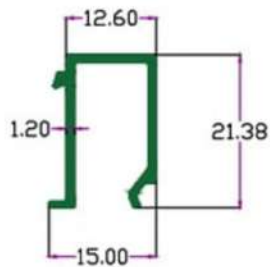

SEC.NO. 4511

Wt. 0.650 TO 0.850 KG./ 12'

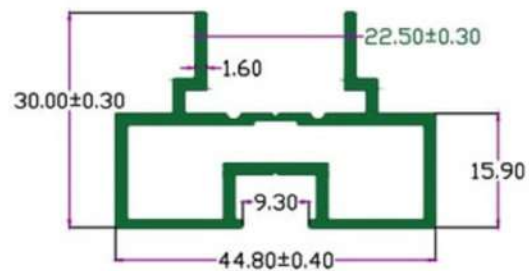

SEC.NO. 4529

Wt. 2.350 TO 2.500 KG./ 12'

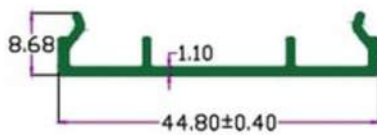

SEC.NO. 4531

Wt. 0.750 TO 0.850 KG./ 12'

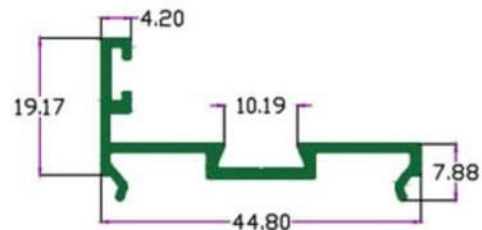

SEC.NO. 4544

Wt. 1.170 TO 1.270 KG./ 12'

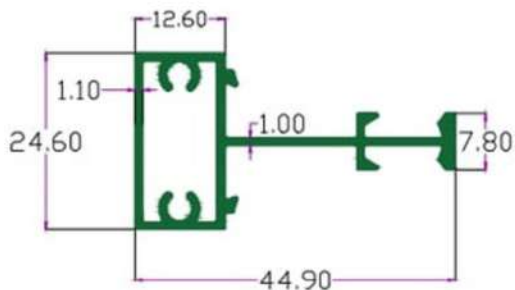

SEC.NO. 4572

Wt. 3.280 TO 3.350 KG./ 12'

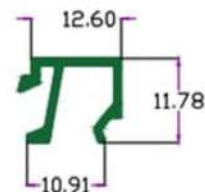

SEC.NO. 4573

Wt. 0.450 TO 0.550 KG./ 12'



SLIM

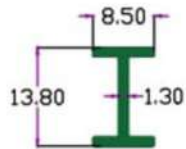

SEC.NO. 4764
Wt. 0.360 TO 0.460 KG./ 12'

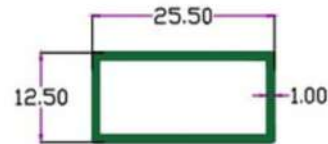

SEC.NO. 4779
Wt. 0.700 TO 0.800 KG./ 12'

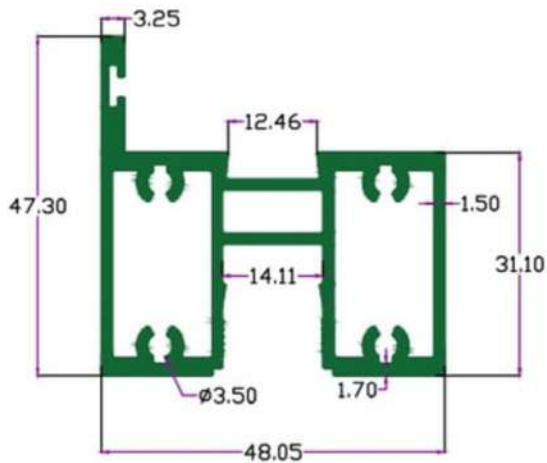

SEC.NO. 4817
Wt. 4.550 TO 4.800 KG./ 12'

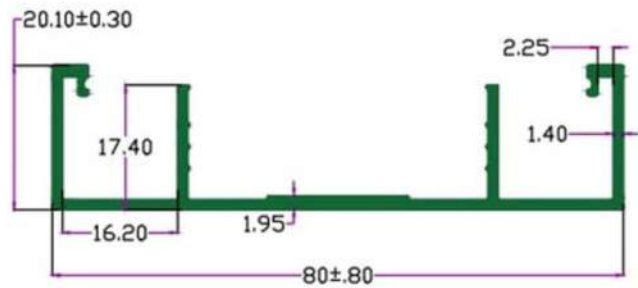

SEC. NO. 3770
Wt. 2.30 TO 2.70 KG / 12'

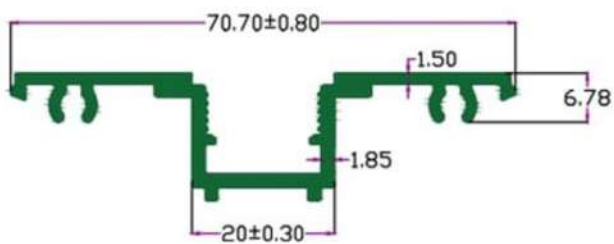

SEC. NO. 3771
Wt. 2.20 TO 2.50 KG / 12'

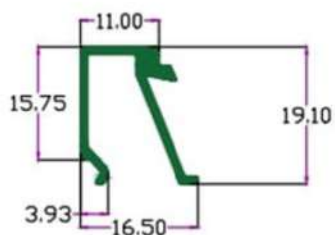

SEC. NO. 3773
Wt. 0.60 TO 0.80 KG / 12'

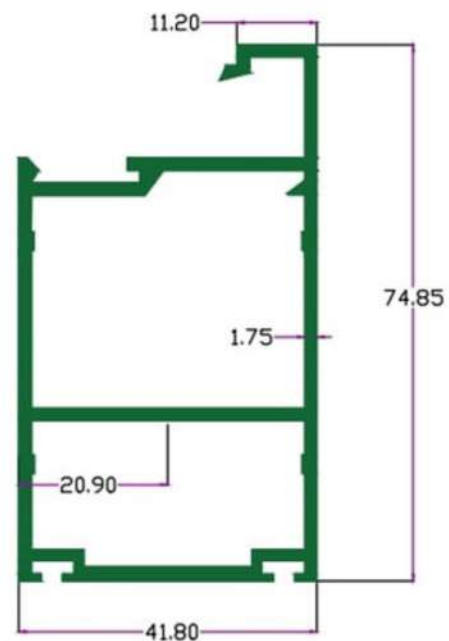

SEC. NO. 3772
Wt. 4.80 TO 5.10 KG / 12'



SLIM

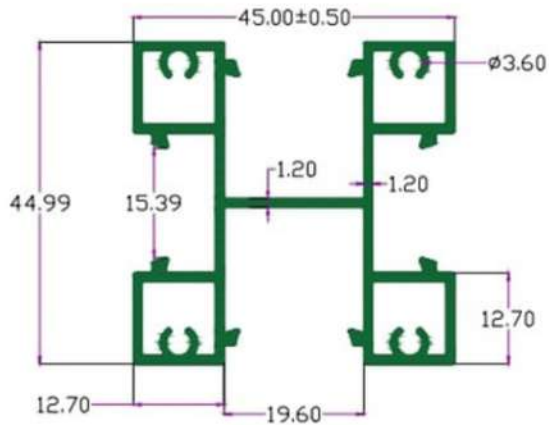

SEC.NO. 4656
Wt. 3.450 TO 3.620 KG./ 12'

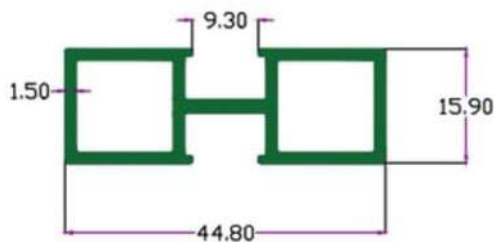

SEC.NO. 4685
Wt. 2.000 TO 2.200 KG./ 12'

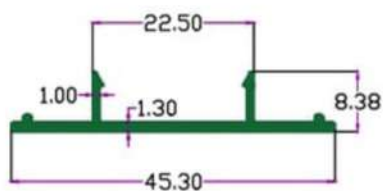

SEC.NO. 4692
Wt. 0.740 TO 0.850 KG./ 12'

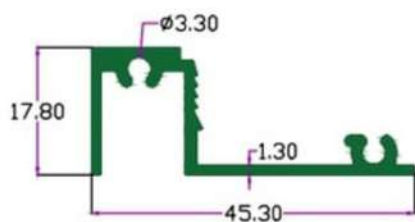

SEC.NO. 4715
Wt. 1.330 TO 1.490 KG./ 12'

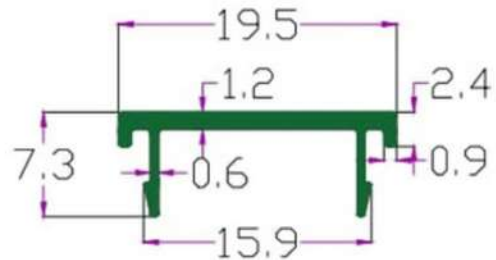

SEC.NO. 4657
Wt. 0.330 TO 0.500 KG./ 12'

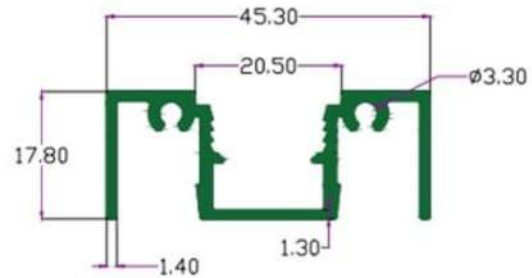

SEC.NO. 4691
Wt. 1.830 TO 2.050 KG./ 12'

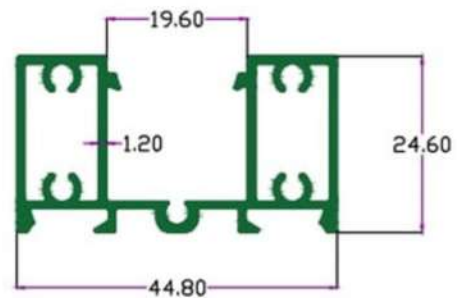

SEC.NO. 4699
Wt. 2.220 TO 2.470 KG./ 12'

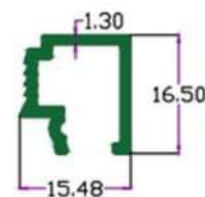

SEC.NO. 4716
Wt. 0.700 TO 0.820 KG./ 12'



INTELLIGENT
ALUMINIUM
itwalpanel.com

SLIM

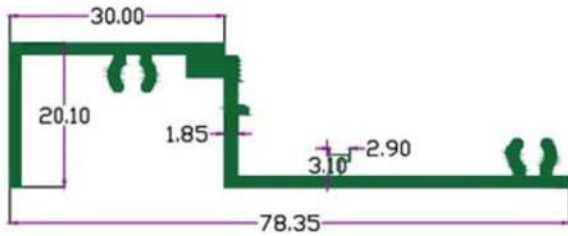

SEC. NO. 3774
Wt. 2.25 TO 2.50 KG / 12'

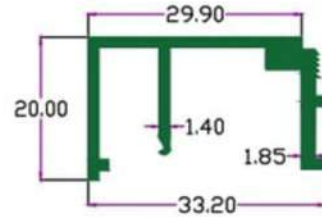

SEC. NO. 3775
Wt. 1.35 TO 1.50 KG / 12'

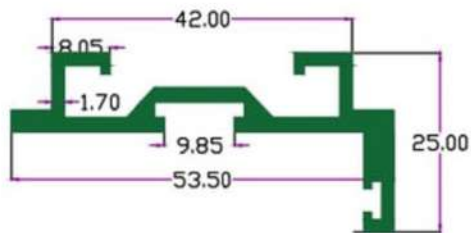

SEC. NO. 3776
Wt. 2.35 TO 2.50 KG / 12'

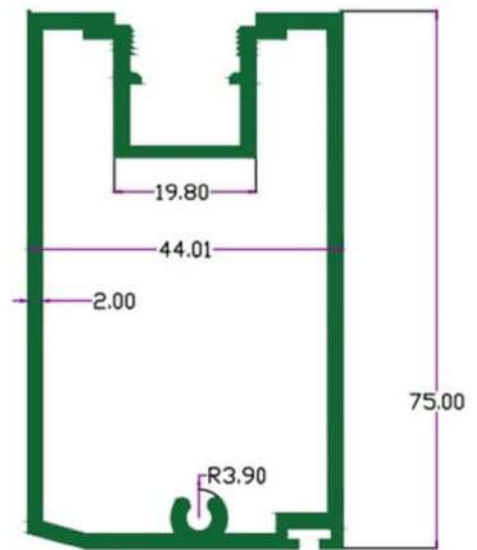

SEC. NO. 3777
Wt. 5.50 TO 5.80 KG / 12'

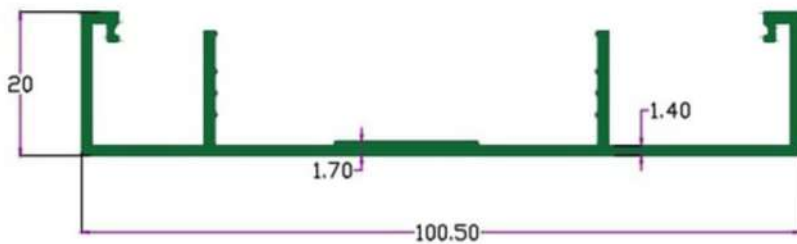

SEC. NO. 3897
Wt. 2.500 TO 2.800 KG. / 12'

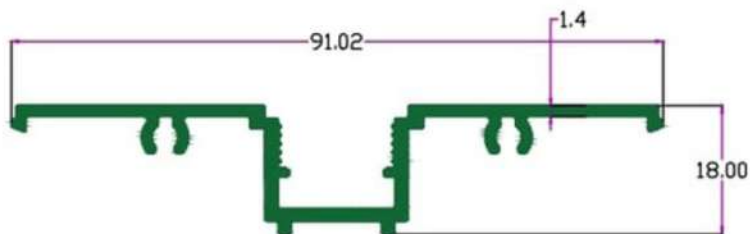

SEC. NO. 3898
Wt. 2.400 TO 1.700 KG. / 12'



INTELLIGENT
ALUMINIUM
itwalpanel.com

SLIM

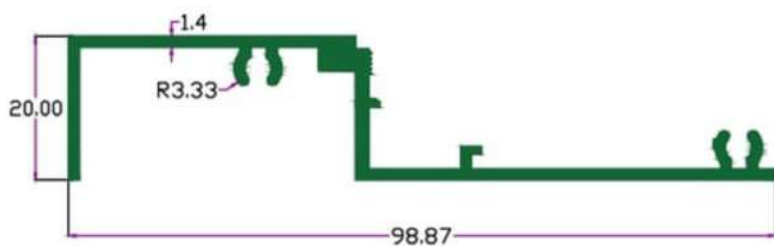

SEC. NO. 3899
Wt.2.400 TO 1.700 KG./ 12'

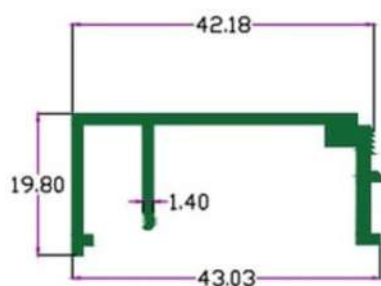

SEC. NO. 3900
Wt.1.400 TO 1.800 KG./ 12'

DOMAL / CASEMENT



INTELLIGENT
ALUMINIUM
itwalpanel.com

30MM CASEMENT SECTIONS

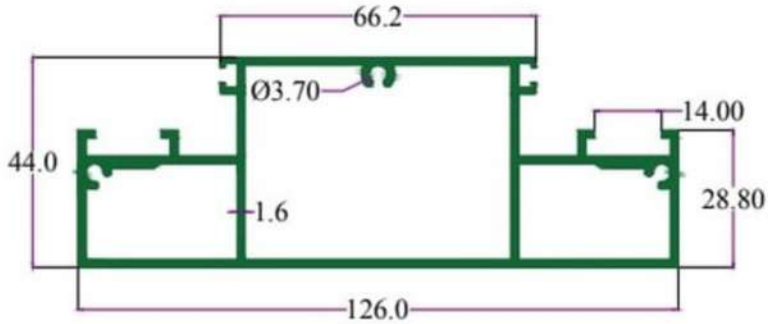

SEC. NO. 3527
WT. 7.100 TO 7.900 KG / 12'

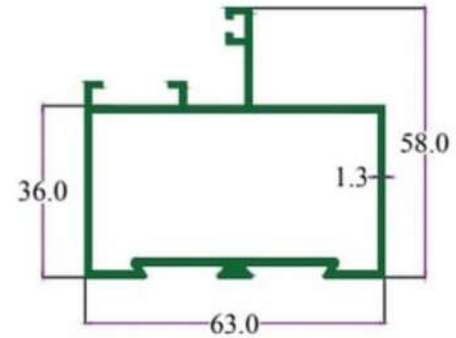

SEC. NO. 3530
WT. 3.100 TO 3.500 KG / 12'

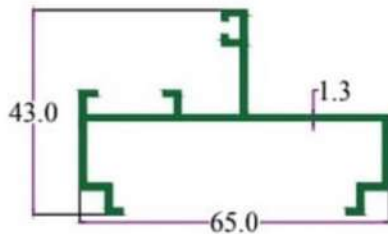

SEC. NO. 3528
WT. 2.050 TO 2.300 KG / 12'

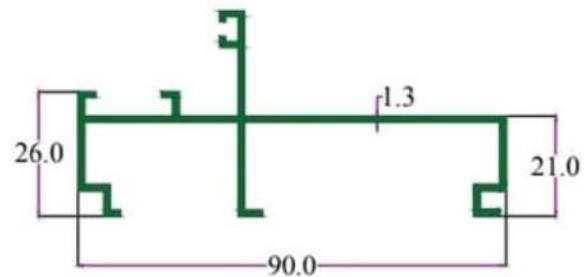

SEC. NO. 3529
WT. 2.700 TO 3.000 KG / 12'

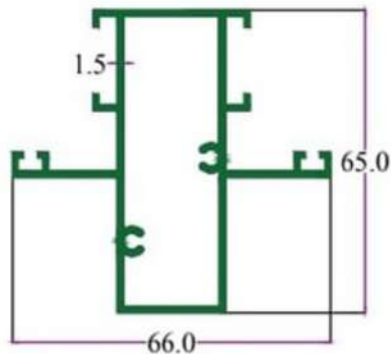

SEC. NO. 3531
WT. 3.800 TO 4.200 KG / 12'

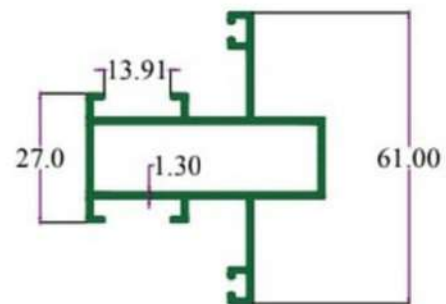

SEC. NO. 3521
WT. 3.000 TO 3.300 KG / 12'

DOMAL / CASEMENT



INTELLIGENT
ALUMINIUM
itwalpanel.com

30MM CASEMENT SECTIONS

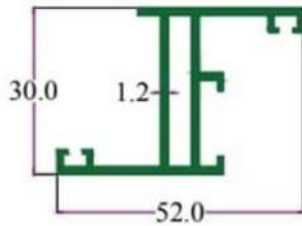

SEC. NO. 3523
WT. 1.650 TO 1.850 KG / 12'

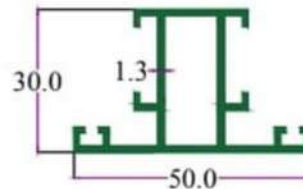

SEC. NO. 3524
WT. 1.900 TO 2.200 KG / 12'

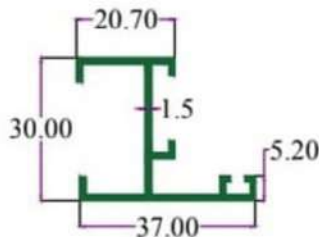

SEC. NO. 3522
WT. 1.550 TO 1.750 KG / 12'

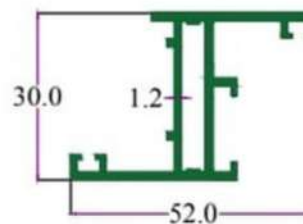

SEC. NO. 3525
WT. 1.650 TO 1.850 KG / 12'

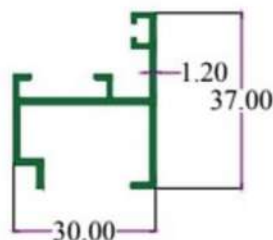

SEC. NO. 3994
WT. 1.300 TO 1.600 KG./12'

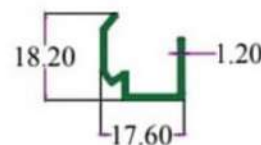

SEC. NO. 3995
WT. 0.500 TO 0.700 KG./12'

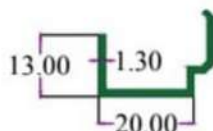

SEC. NO. 3526
WT. 0.630 TO 0.710 KG/12'

DOMAL / CASEMENT



INTELLIGENT
ALUMINIUM
itwalpanel.com

27MM SLIDING WINDOWS

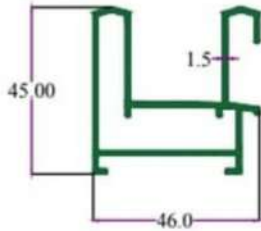

SEC. NO. 3313
WT. 3.270 TO 3.550 KG./ 12'

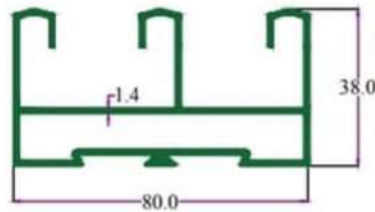

SEC. NO. 3316
WT. 4.290 TO 4.500 KG./ 12'

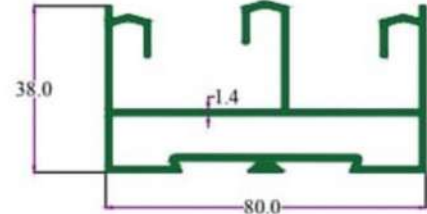

SEC. NO. 3314
WT. 4.30 TO 4.50 KG./ 12'

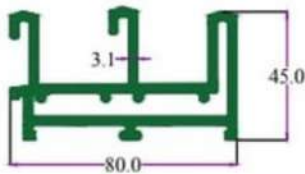

SEC. NO. 3694
WT. 9.60 TO 10.60 KG / 12'

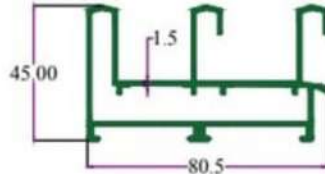

SEC. NO. 3311
WT. 5.200 TO 5.400 KG./ 12'

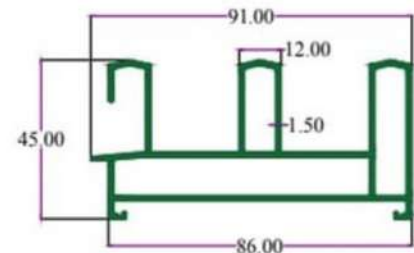

SEC. NO. 4272
WT. 5.750 TO 6.100 KG./ 12'

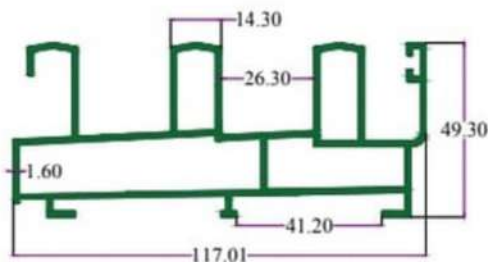

SEC. NO. 3320
WT. 8.000 TO 8.250 KG./ 12'

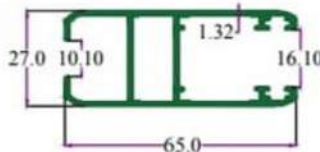

SEC. NO. 3315
WT. 2.720 TO 3.000 KG./12'

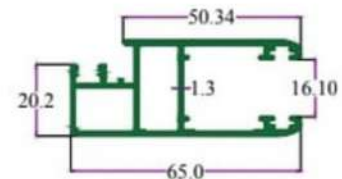

SEC. NO. 3331
WT. 3.100 TO 3.400 KG./ 12'



SEC. NO. 3695
WT. 5.750 TO 6.100 KG./ 12'

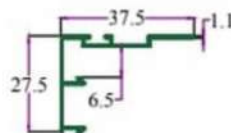

SEC. NO. 3312
WT. 0.940 TO 1.110 KG./12'

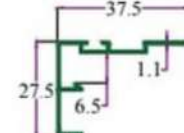

SEC. NO. 3312
WT. 0.940 TO 1.100 KG./ 12'

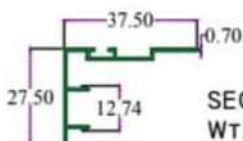

SEC. NO. 4421
WT. 0.600 TO 0.850 KG./ 12'

DOMAL / CASEMENT



INTELLIGENT
ALUMINIUM
itwalpanel.com

37MM SLIDING WINDOWS

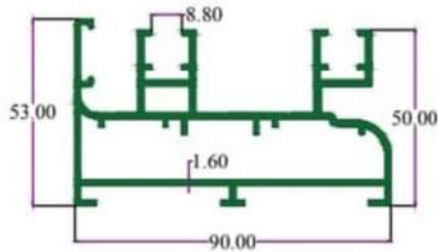

SEC. NO. 4706
WT. 6.700 TO 6.950 KG. / 12'

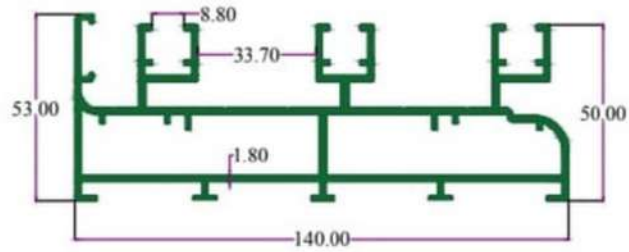

SEC. NO. 4707
WT. 10.540 TO 10.800 KG. / 12'

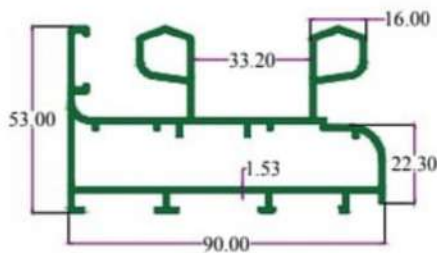

SEC. NO. 4712
WT. 6.440 TO 6.620 KG. / 12'

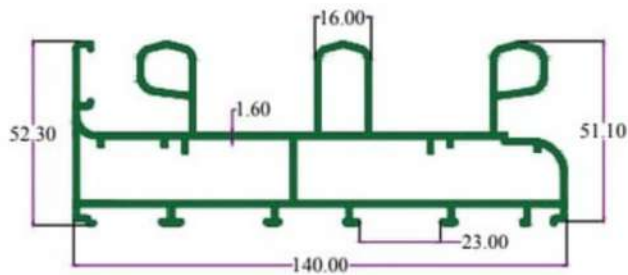

SEC. NO. 4713
WT. 9.810 TO 10.120 KG. / 12'

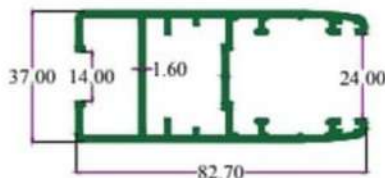

SEC. NO. 4708
WT. 4.860 TO 5.050 KG. / 12'

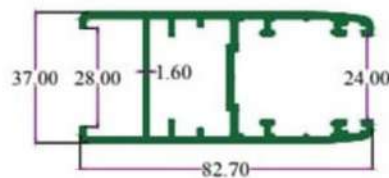

SEC. NO. 4709
WT. 4.610 TO 4.850 KG. / 12'

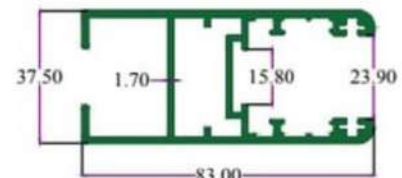

SEC. NO. 4748
WT. 5.240 TO 5.500 KG. / 12'

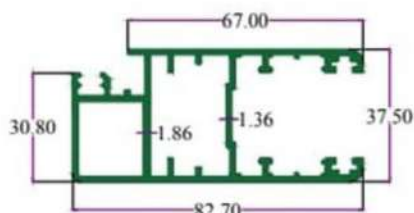

SEC. NO. 4711
WT. 4.820 TO 5.050 KG. / 12'

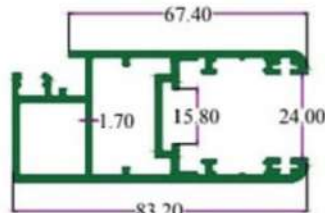

SEC. NO. 4747
WT. 5.700 TO 5.950 KG. / 12'

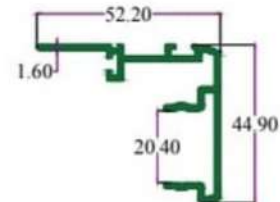

SEC. NO. 4710
WT. 2.420 TO 2.610 KG. / 12'

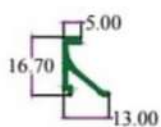

SEC. NO. 4717
WT. 0.420 TO 0.550 KG. / 12'

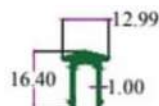

SEC. NO. 4705
WT. 0.550 TO 0.650 KG. / 12'

DOMAL / CASEMENT



INTELLIGENT
ALUMINIUM
itwalpanel.com

29MM SLIDING WINDOWS

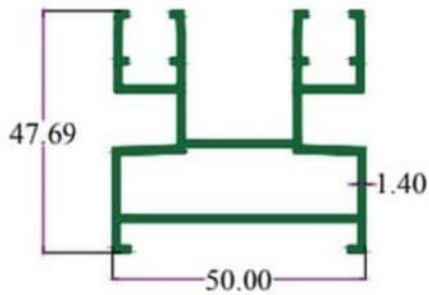

SEC.NO. 4928
WT. 3.600 TO 3.900 KG./ 12'

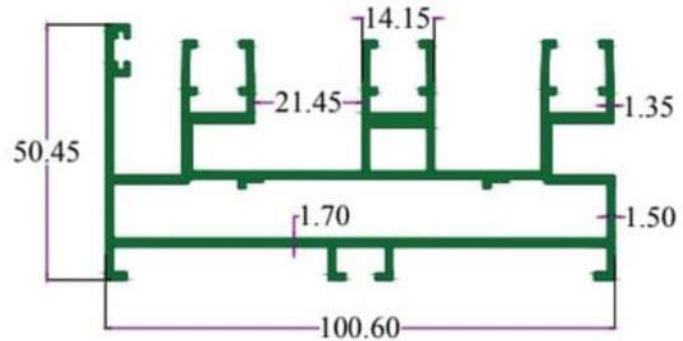

SEC.NO. 4927
WT. 7.615 TO 7.915 KG./ 12'

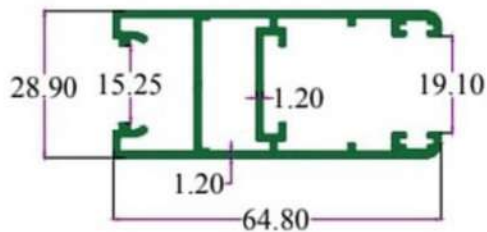

SEC.NO. 4924
WT. 2.990 TO 3.300 KG./ 12'

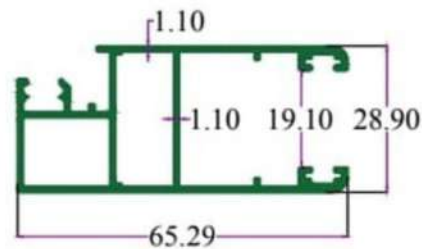

SEC.NO. 4925
WT. 2.750 TO 3.050 KG./ 12'

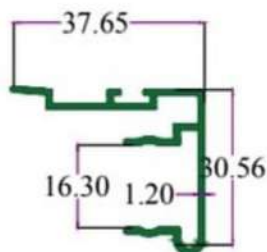

SEC.NO. 4926
WT. 1.310 TO 1.450 KG./ 12'

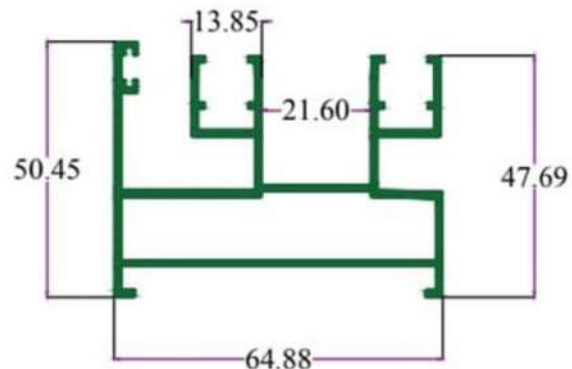

DOMAL / CASEMENT



INTELLIGENT
ALUMINIUM
itowalpanel.com

32MM SLIDING WINDOWS

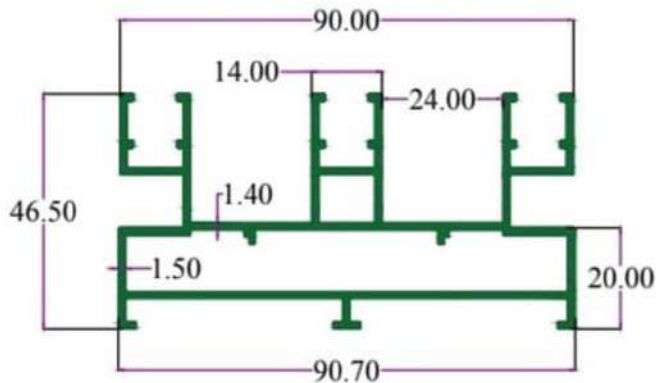

SEC.NO. 4888
WT. 5.900 TO 6.150 KG./ 12'

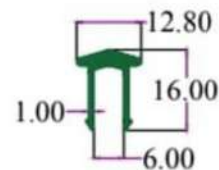

SEC.NO. 4890
WT. 0.555 TO 0.660 KG./ 12'

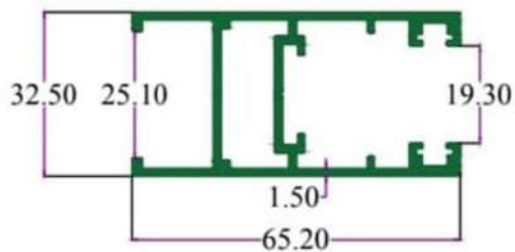

SEC.NO. 4889
WT. 3.700 TO 3.900 KG./ 12'

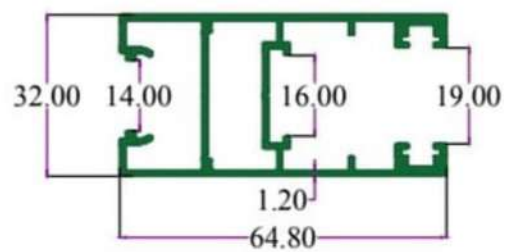

SEC.NO. 4892
WT. 3.360 TO 3.560 KG./ 12'

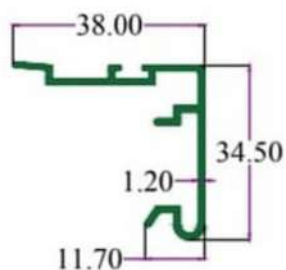

SEC.NO. 4891
WT. 1.230 TO 1.380 KG./ 12'

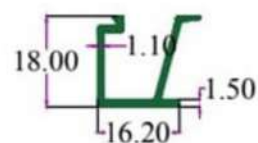

SEC.NO. 4893
WT. 0.580 TO 0.680 KG./ 12'

DOMAL / CASEMENT



INTELLIGENT
ALUMINIUM
itwalpanel.com

32MM SLIDING WINDOWS

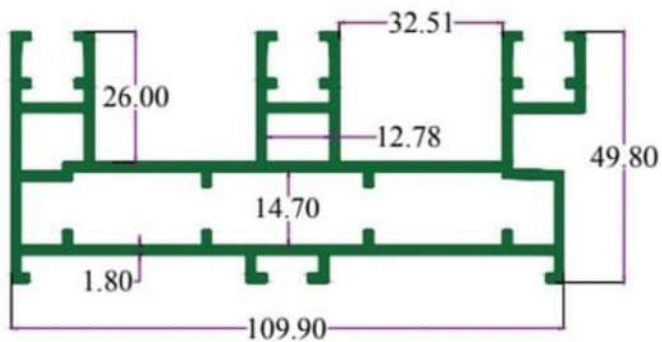

SEC.NO. 4740
WT. 9.020 TO 9.300 KG./ 12'

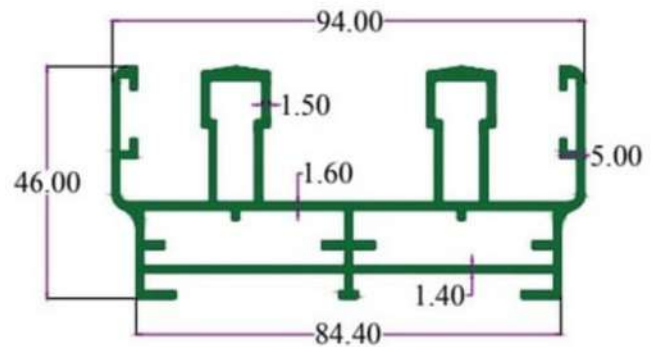

SEC.NO. 4345
WT. 7.100 TO 7.300 KG./ 12'

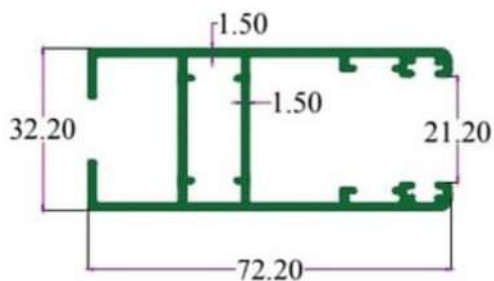

SEC.NO. 4351
WT. 3.760 TO 3.950 KG./ 12'

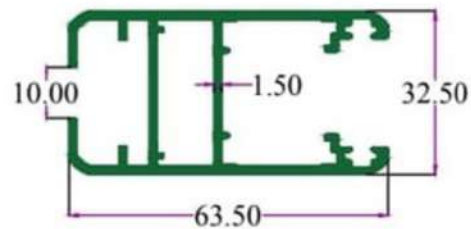

SEC.NO. 3319
WT. 3.850 TO 4.050 KG./12'

DOMAL / CASEMENT



INTELLIGENT
ALUMINIUM
itwalpanel.com

FOLDING SECTIONS

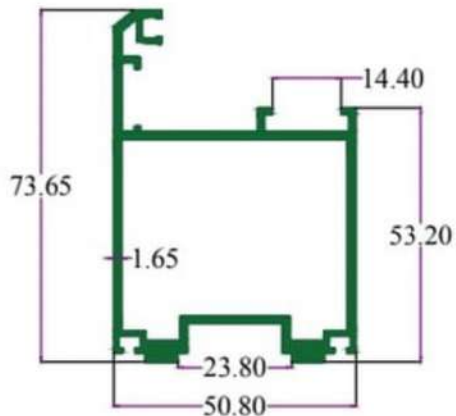

SEC. NO. 5006
WT. 4.735 TO 4.950 KG./ 12'

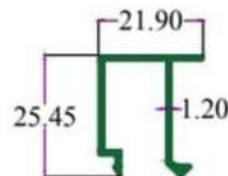

SEC. NO. 5007
WT. 0.940 TO 1.100 KG./ 12'

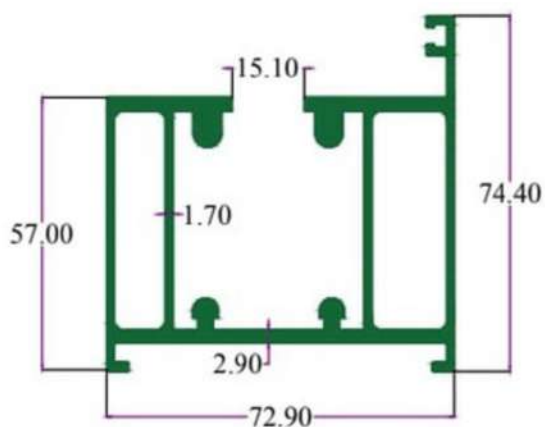

SEC. NO. 5008
WT. 8.860 TO 9.000 KG./ 12'

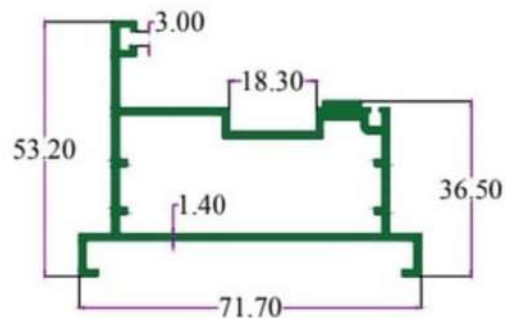

SEC. NO. 5009
WT. 3.625 TO 3.850 KG./ 12'

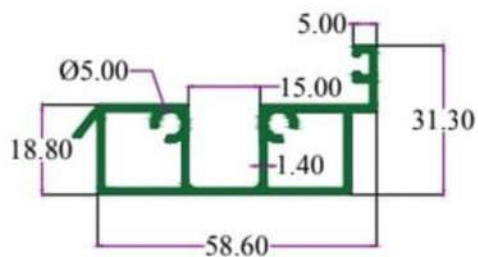

SEC. NO. 5010
WT. 2.900 TO 3.100 KG./ 12'

DOMAL / CASEMENT



INTELLIGENT
ALUMINIUM
itowalpanel.com

CASEMENT SECTIONS

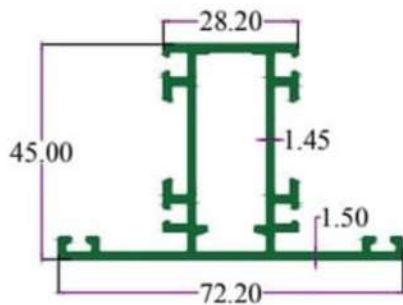

SEC.NO. 4930
WT. 3.720 TO 3.980 KG./ 12'

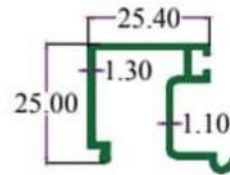

SEC.NO. 4931
WT. 1.200 TO 1.350 KG./ 12'

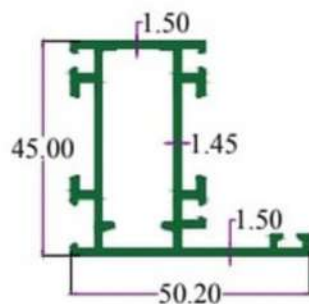

SEC.NO. 4929
WT. 3.225 TO 3.500 KG./ 12'

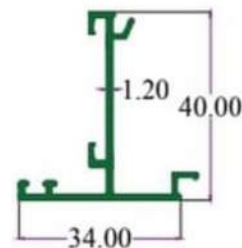

SEC. NO. 4270
WT. 1.200 TO 1.400 KG./ 12'

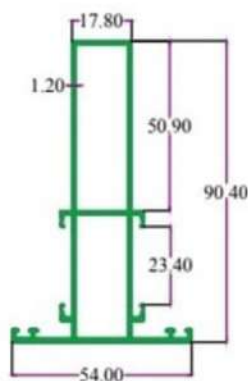

SEC. NO. 4271
WT. 3.500 TO 3.800 KG./ 12'

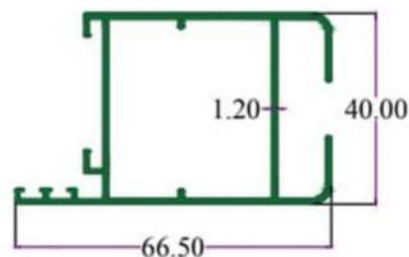

SEC. NO. 3464
WT. 3.500 TO 3.700 KG./ 12'

DOMAL / CASEMENT



INTELLIGENT
ALUMINIUM
itowalpanel.com

MISCELLANEOUS SLIDING WINDOWS

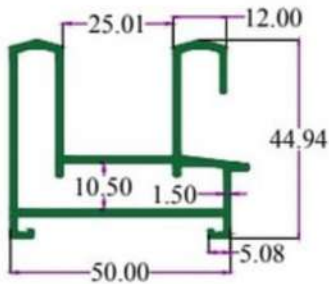

SEC.NO. 4845
WT. 3.650 TO 3.870 KG./ 12'

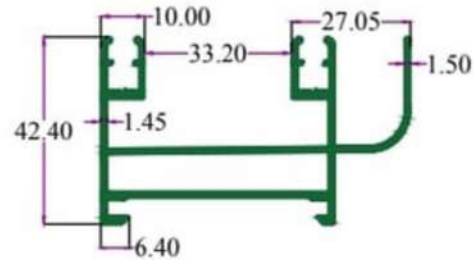

SEC.NO. 4843
WT. 4.180 TO 4.400 KG./ 12'

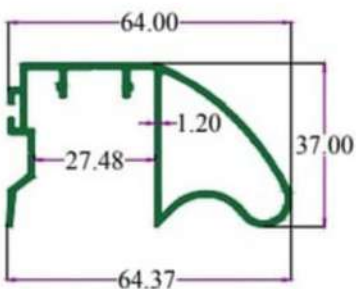

SEC.NO. 4847
WT. 2.580 TO 2.850 KG./ 12'

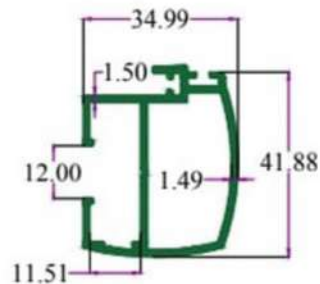

SEC.NO. 4844
WT. 2.630 TO 2.850 KG./ 12'

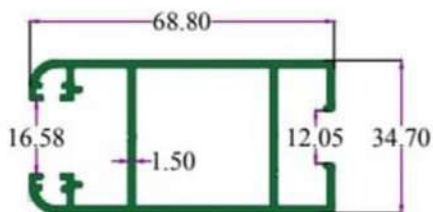

SEC.NO. 4842
WT. 3.760 TO 4.000 KG./ 12'

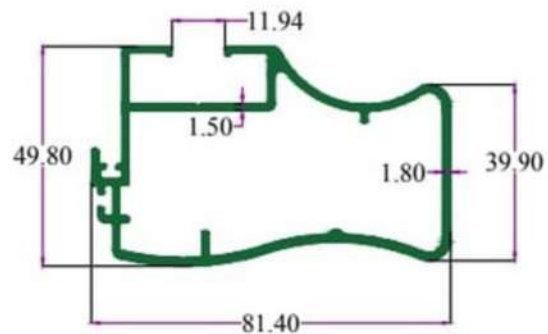

SEC.NO. 4848
WT. 4.880 TO 5.130 KG./ 12'

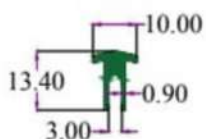

SEC.NO. 4846
WT. 0.470 TO 0.570 KG./ 12'

DOMAL / CASEMENT



INTELLIGENT
ALUMINIUM
itwalpanel.com

35MM CASEMENT SECTIONS

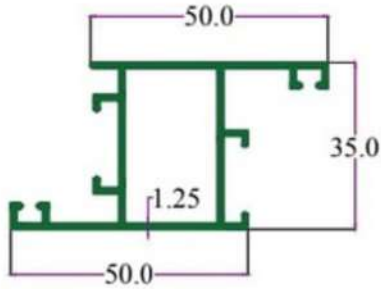

SEC. No. 3284
WT. 2.540 TO 2.800 KG./ 12'

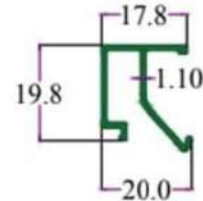

SEC. No. 3285
WT. 0.730 TO 0.850 KG./12'

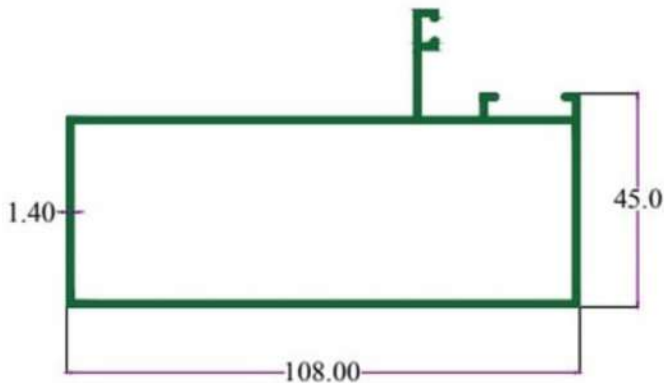

SEC. No. 3286
WT. 4.600 TO 4.900 KG./ 12'

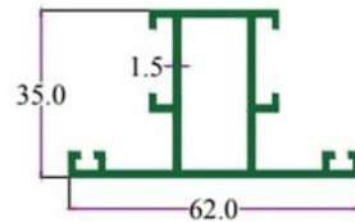

SEC. NO. 3515
WT. 2.300 TO 2.600 KG / 12'

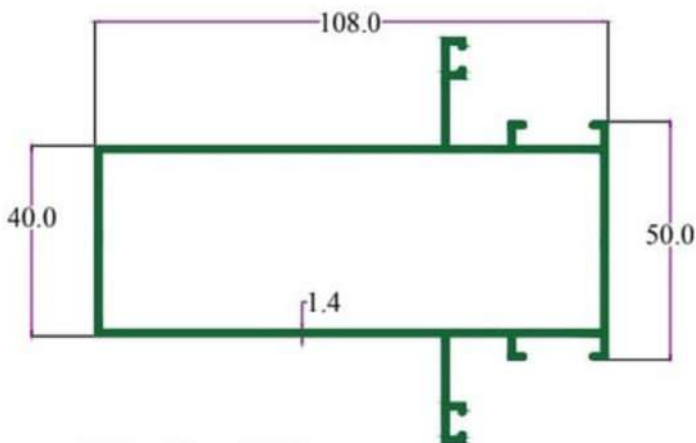

SEC. No. 3287
WT. 5.240 TO 5.500 KG./ 12'

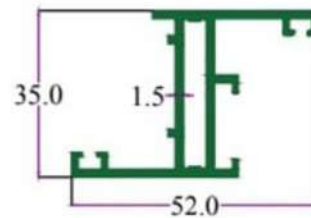

SEC. NO. 3516
WT. 2.200 TO 2.500 KG / 12'

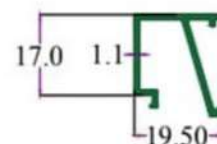

SEC. NO. 3518
WT. 0.700 TO 0.800 KG

DOMAL / CASEMENT



INTELLIGENT
ALUMINIUM
itowalpanel.com

35MM CASEMENT SECTIONS

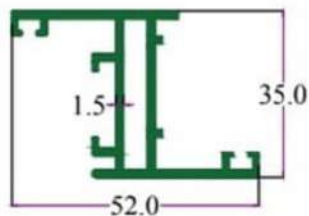

SEC. NO. 3517
WT. 2.300 TO 2.600 KG / 12'

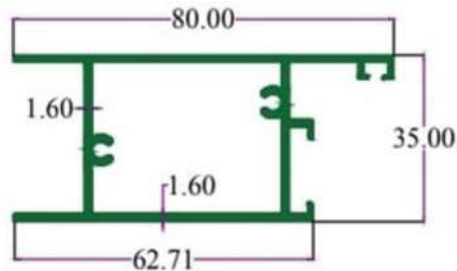

SEC. NO. 3519
WT. 3.600 TO 4.000 KG / 12'

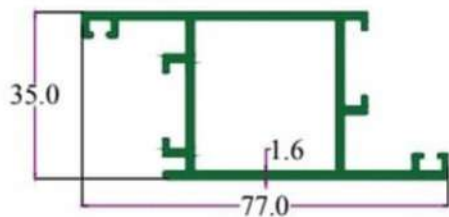

SEC. NO. 3520
WT. 3.100 TO 3.500 KG / 12'

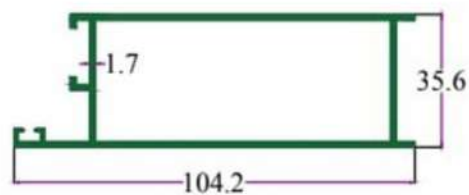

SEC. NO. 2064
WT. 4.647 TO 8.000 KG. / 12'

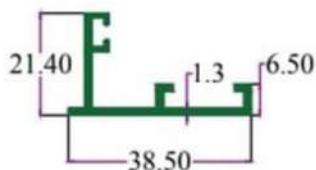

SEC. NO. 2065
WT. 1.000 TO 1.200 KG. / 12'

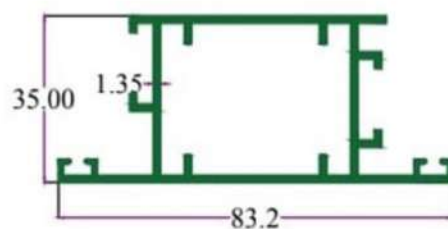

SEC. NO. 2067
WT. 3.622 TO 3.800 KG. / 12'

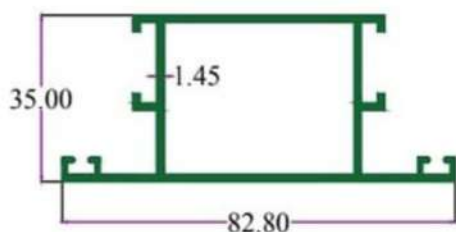

SEC. NO. 2066
WT. 3.400 TO 3.550 KG. / 12'

DOMAL / CASEMENT



INTELLIGENT
ALUMINIUM
itwalpanel.com

FOLDING SECTIONS

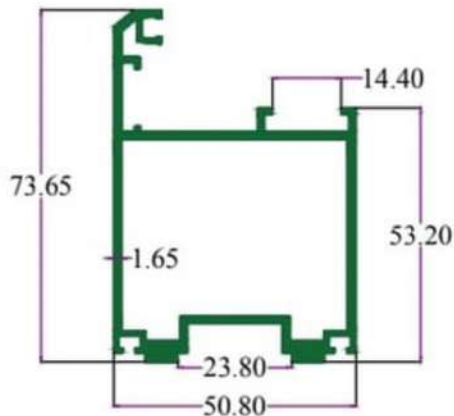

SEC. NO. 5006
WT. 4.735 TO 4.950 KG./ 12'

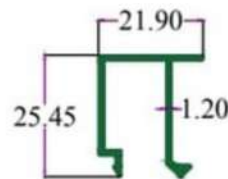

SEC. NO. 5007
WT. 0.940 TO 1.100 KG./ 12'

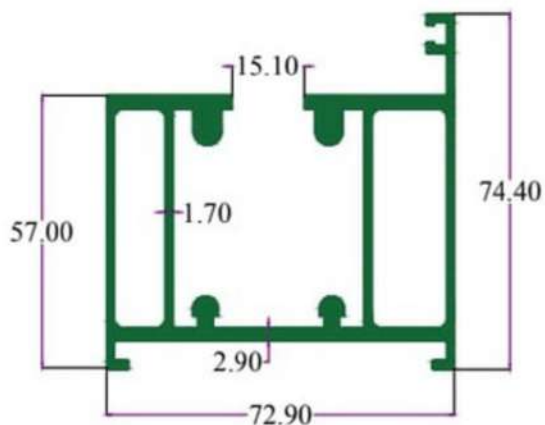

SEC. NO. 5008
WT. 8.860 TO 9.000 KG./ 12'

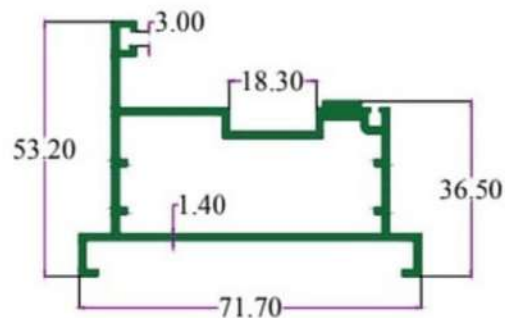

SEC. NO. 5009
WT. 3.625 TO 3.850 KG./ 12'

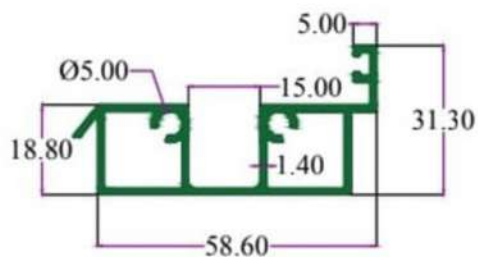

SEC. NO. 5010
WT. 2.900 TO 3.100 KG./ 12'

DOMAL / CASEMENT



INTELLIGENT
ALUMINIUM
itowalpanel.com

38MM CASEMENT SECTIONS

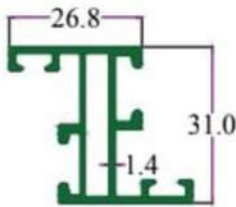

SEC. NO. 2180

WT. 1.900 TO 2.000 KG./ 12'

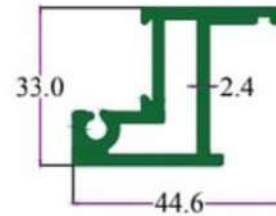

SEC. No. 3154

WT. 3.200 TO 3.540 KG./ 12'

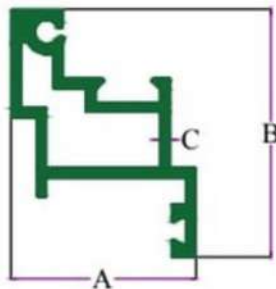

S. No.	Section No.	A IN mm.	B IN mm.	T IN mm.	Weight. (KG./ 12')
1	2183	44.0	45.6	1.20	2.500-3.000
2	2184	44.0	45.6	1.80	2.500-3.000

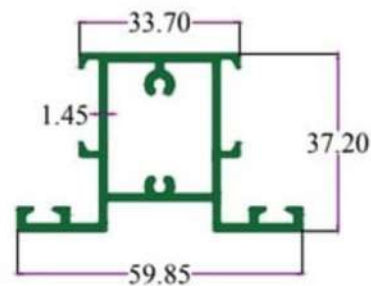

SEC. NO. 3263

WT. 2.906 TO 3.212 KG./ 12'

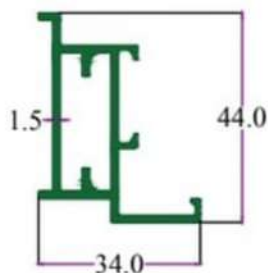

SEC. NO. 3261

WT. 2.026 TO 2.400 KG./ 12'

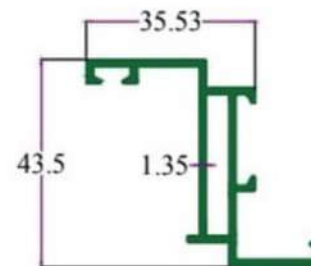

SEC. NO. 3262

WT. 2.070 TO 2.300 KG./ 12'

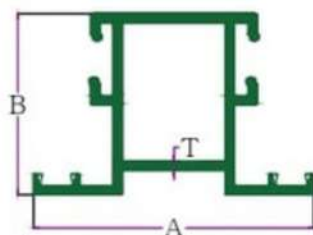

MULLION SECTION

S. No.	Section No.	A IN mm.	B IN mm.	T IN mm.	Weight. (KG./ 12')
1	2101	59.00	38.00	1.40	2.500-2.700
2	2102	59.00	38.00	1.60	2.800-3.100
3	2103	59.00	38.00	1.85	3.200-3.700
4	2104	59.00	38.00	2.00	3.800-4.400

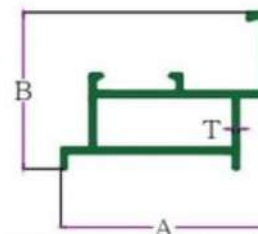

Z LINE SECTION

S. No.	Section No.	A IN mm.	B IN mm.	T IN mm.	Weight. (KG./ 12')
1	2105	43.50	33.00	1.30	1.700-2.000
2	2106	43.50	33.00	1.55	2.100-2.300
3	2107	43.50	33.00	1.80	2.400-2.700
4	2108	43.50	33.00	2.10	3.000-

DOMAL / CASEMENT



INTELLIGENT
ALUMINIUM
itowalpanel.com

38MM CASEMENT SECTIONS

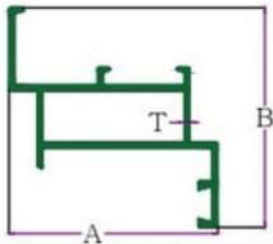

Z HOLLOW SECTION

S. No.	Section No.	A IN mm.	B IN mm.	T IN mm.	Weight (KG./ 12')
1	2109	44.00	46.00	1.20	1.800-2.000
2	2110	44.00	46.00	1.40	2.100-2.300
3	2111	44.00	46.00	1.60	2.400-2.700
4	2112	44.00	46.00	1.80	3.200-3.500
5	2119	44.00	46.00	1.10	1.600-1.800
6	3262	43.50	49.10	1.35	2.070-2.300

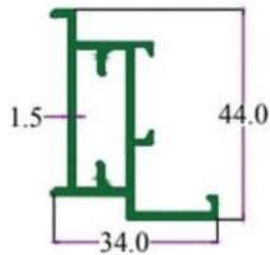

SEC. NO. 3261
WT. 2.026 TO 2.400 KG./ 12'

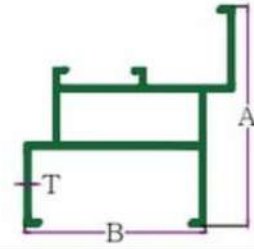

Z BOX SECTION

S. No.	Section No.	A IN mm.	B IN mm.	T IN mm.	Weight (KG./ 12')
1	2113	46.00	38.00	1.20	1.800-2.000
2	2114	46.00	38.00	1.40	2.100-2.300
3	2115	46.00	38.00	1.60	2.400-2.700

Z CLIP SECTION

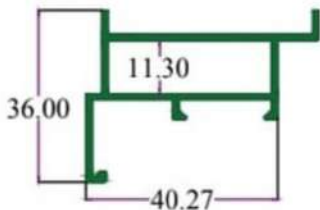

SEC. NO. 2116
WT. 1.800 TO 2.000 KG./ 12'

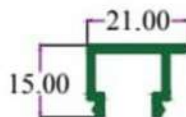

SEC. NO. 2117
WT. 0.400 TO 0.600 KG./ 12'

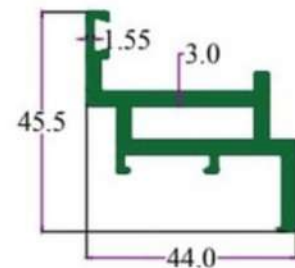

SEC. NO. 2118
WT. 3.900 TO 4.100 KG./ 12'

DOMAL / CASEMENT



INTELLIGENT
ALUMINIUM
itowalpanel.com

40MM CASEMENT SECTIONS

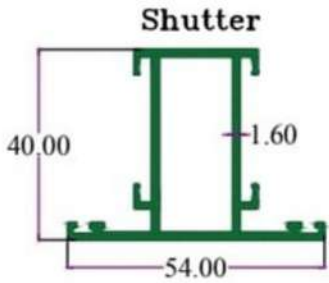

SEC.NO. 3332N / 4766
WT. 2.800 To 3.000 KG/12'

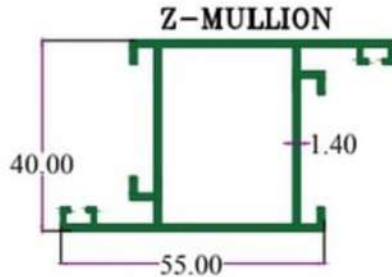

SEC.NO. 3339
WT. 3.050 To 3.250 KG/12'

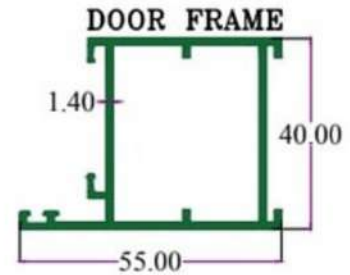

SEC.NO. 3334N
WT. 2.650 To 2.850 KG/12'

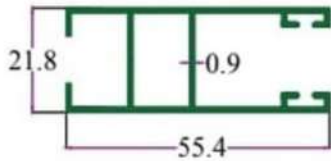

SEC.NO. 3333
WT. 2.800 TO 3.00 KG/ 12'

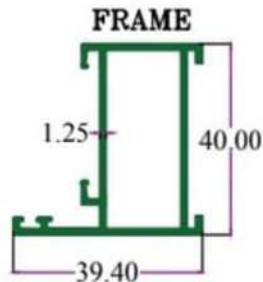

SEC.NO. 3337N
WT. 2.000 To 2.200 KG/12'

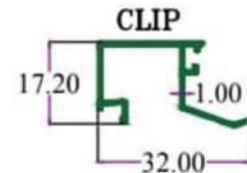

SEC.NO. 3341N
WT. 0.750 To 0.850 KG/12'

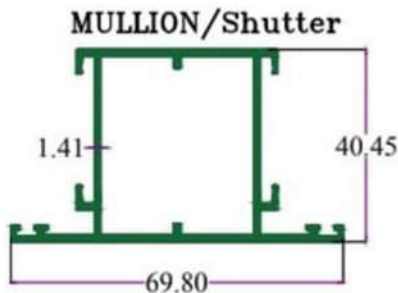

SEC.NO. 3338N
WT. 3.300 To 3.500 KG/12'

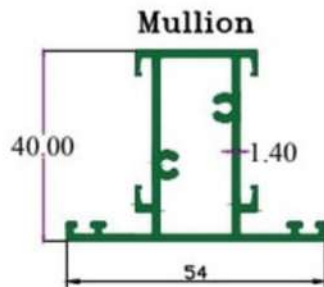

SEC. NO. 3481
WT. 2.600 TO 2.900 KG/12'

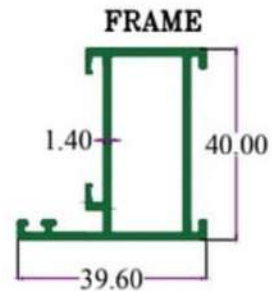

SEC. NO. 3482
WT. 2.100 TO 2.400 KG/12'

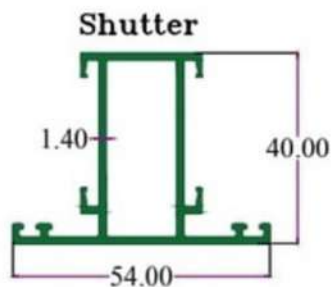

SEC. NO. 3483
WT. 2.350 TO 2.650 KG/12'

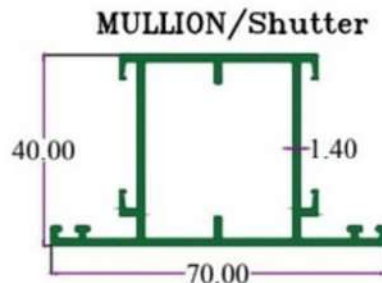

SEC. NO. 3484
WT. 3.950 TO 3.250 KG/12'

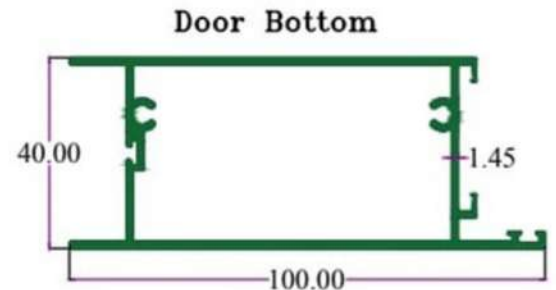

SEC. NO. 3485
WT. 4.100 TO 4.600 KG/12'

DOMAL / CASEMENT



INTELLIGENT
ALUMINIUM
itwalpanel.com

40MM CASEMENT SECTIONS

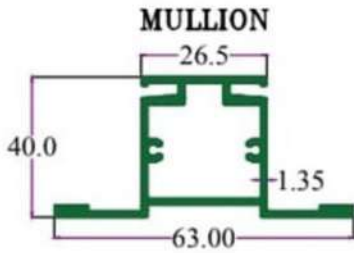

SEC. NO. 2051
WT. 3.900 TO 4.200 KG/15'

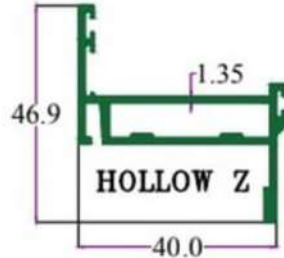

S. No.	Section No.	A IN mm.	B IN mm.	Weight. (KG/ 15')
1	2052 L	46.90	40.00	2.700-2.900
2	2052 M	46.90	40.00	3.400-3.600
3	2052 H	46.90	40.00	4.700-4.900

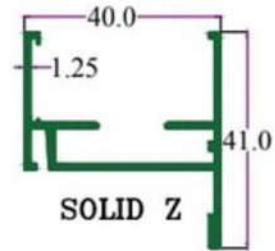

SEC. NO. 2053
WT. 1.700 TO 1.900 KG./ 12'

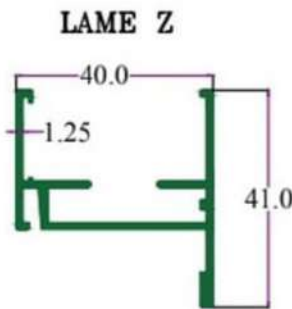

SEC. NO. 2054
WT. 2.900 TO 3.100 KG./ 15'

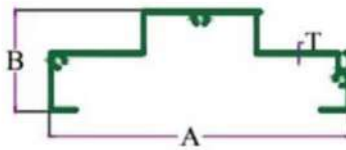

S. No.	Section No.	A IN mm.	B IN mm.	T IN mm.	Weight. (KG/ 12')
1	2056	125.78	39.7	1.50	1.010-1.250
2	2057	125.78	39.7	3.00	2.024-2.300

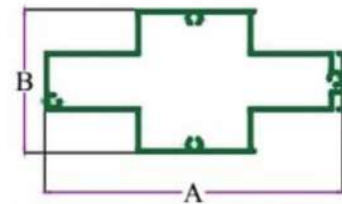

S. No.	Section No.	A IN mm.	B IN mm.	T IN mm.	Weight. (KG/ 12')
1	2058	125.78	58.40	1.50	1.640-1.850
2	2059	125.78	58.40	3.00	3.290-3.450

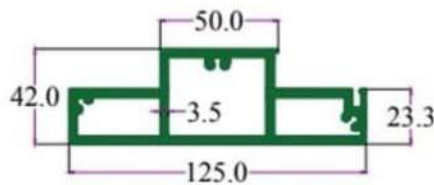

S. No.	Section No.	A IN mm.	B IN mm.	Weight. (KG/ 15')
1	2060	125	42.00	13.00-13.50
2	2069	125	42.00	9.800-10.50
3	3491	125	42.00	11.500-11.800

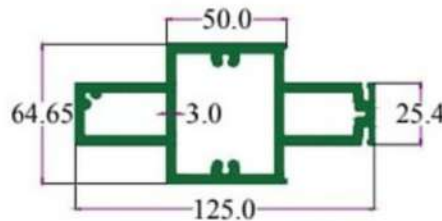

S. No.	Section No.	A IN mm.	B IN mm.	Weight. (KG/ 15')
1	2061	125	64.65	5.000-16.300
2	3492	125	64.65	11.600-11.900

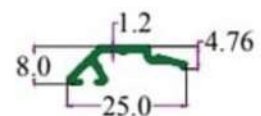

SEC. NO. 3460
WT. 0.450 TO 0.550 KG/12'

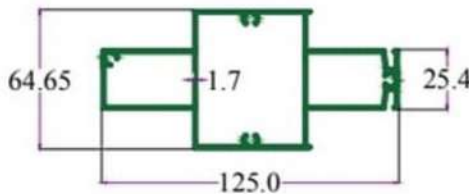

SEC. NO. 2062
WT. 7.800 TO 8.000 KG/12'

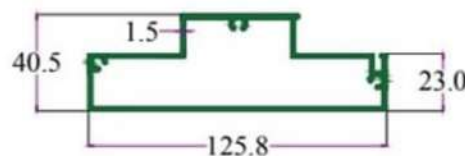

SEC. NO. 2063
WT. 5.260 TO 5.450 KG/12'

DOMAL / CASEMENT



INTELLIGENT
ALUMINIUM
itwalpanel.com

42MM CASEMENT SECTIONS

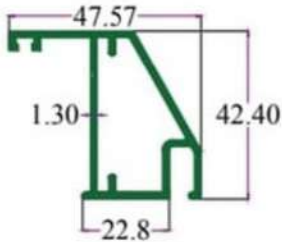

SEC. NO. 2181
WT. 1.900 TO 2.200 KG/12'

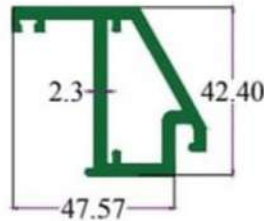

SEC. NO. 2182
WT. 3.950 TO 4.100 KG/15'

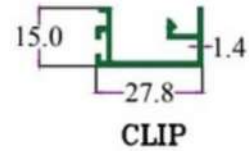

SEC. NO. 2164
WT. 1.050 TO 1.240 K./15'

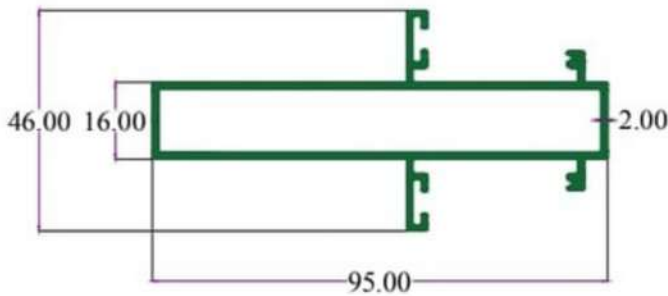

SEC. NO. 2201
WT. 3.900 TO 4.400 KG/15'

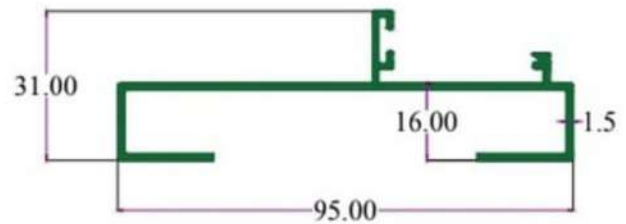

SEC. NO. 2202
WT. 2.600 TO 3.100 KG/15'

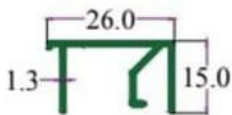

SEC. NO. 2203
WT. 1.050 TO 1.400 KG/15'

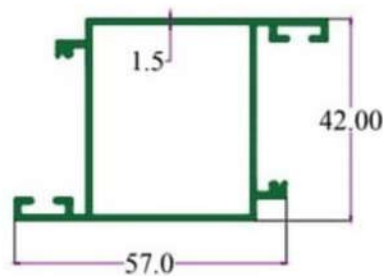

SEC. NO. 2204
WT. 2.600 TO 3.100 KG/15'

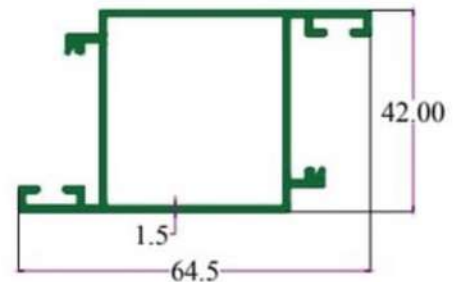

SEC. NO. 2205
WT. 3.250 TO 3.750 KG/15'

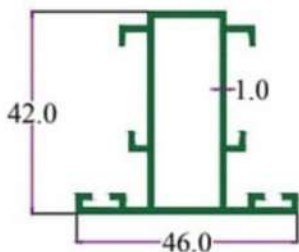

SEC. NO. 2161
WT. 2.200 TO 2.700 KG/15'

MULLION

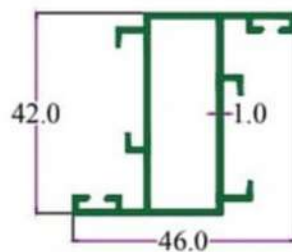

SEC. NO. 2162
WT. 2.300 TO 2.800 KG/15'

HOLLOW-Z

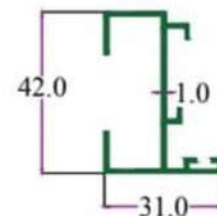

SEC. NO. 2163
WT. 2.200 TO 2.500 KG/15'

LAME-Z

DOMAL / CASEMENT



INTELLIGENT
ALUMINIUM
itowalpanel.com

50MM CASEMENT SECTIONS

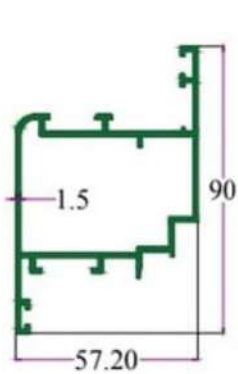

SEC. NO. 3940
WT. 4.400 TO 4.80 KG/12'

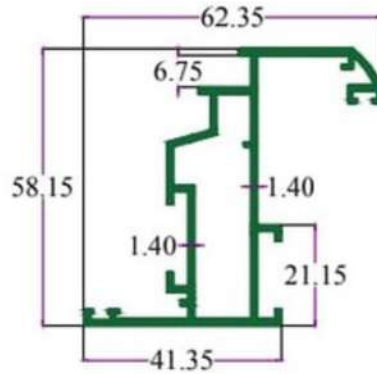

SEC. NO. 4768
WT. 3.320 TO 3.520 KG/12'

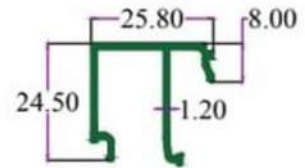

SEC. NO. 4770
WT. 1.020 TO 1.150 KG/12'

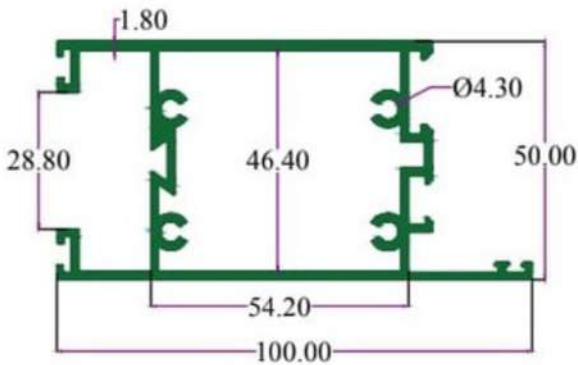

SEC. NO. 4769
WT. 6.550 TO 6.800 KG/12'

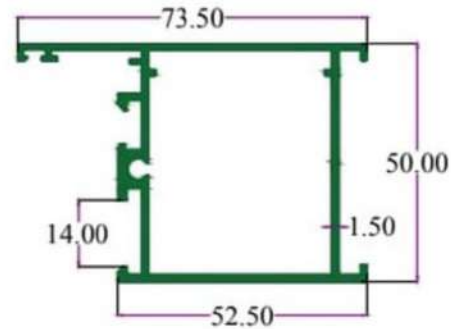

SEC. NO. 4771
WT. 3.320 TO 3.520 KG/12'

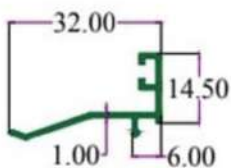

SEC. NO. 4773
WT. 0.600 TO 0.700 KG/12'

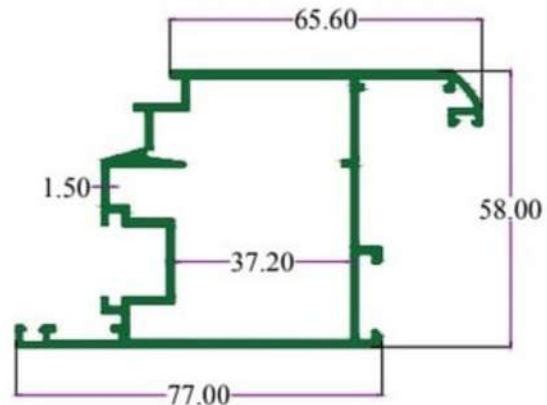

SEC. NO. 4774
WT. 5.150 TO 5.400 KG/12'

DOMAL / CASEMENT



INTELLIGENT
ALUMINIUM
itowalpanel.com

50MM CASEMENT SECTIONS

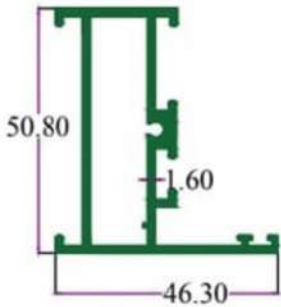

SEC. NO. 3778
WT. 3.600 TO 3.800 KG/12'

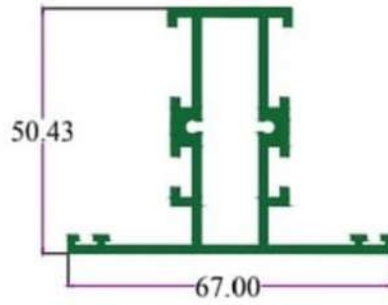

SEC. NO. 3779
WT. 4.50 TO 4.80 KG/12'

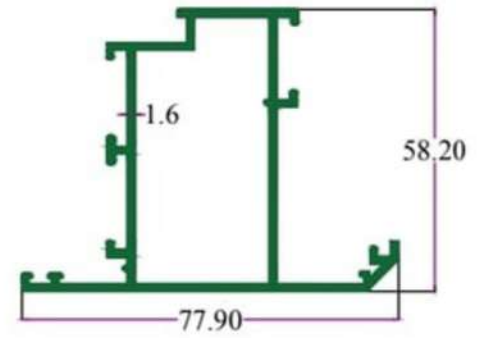

SEC. NO. 3780
WT. 4.200 TO 4.500 KG/12'

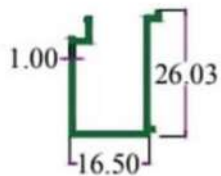

SEC. NO. 3781
WT. 0.70 TO 0.90 KG/12'

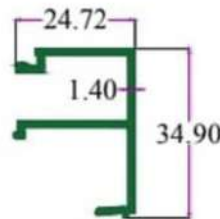

SEC. NO. 3782
WT. 1.20 TO 1.50 KG/12'

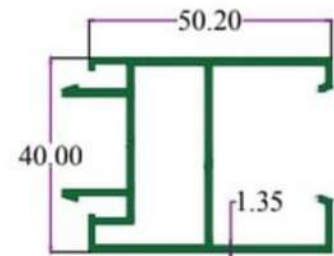

SEC. NO. 3783
WT. 2.850 TO 3.00 KG/12'

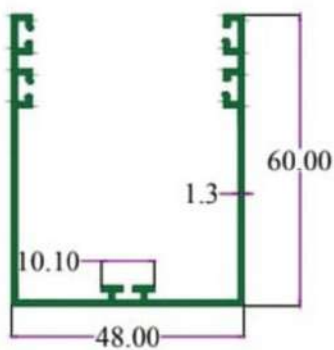

SEC. NO. 3784
WT. 2.600 TO 2.900 KG/12'

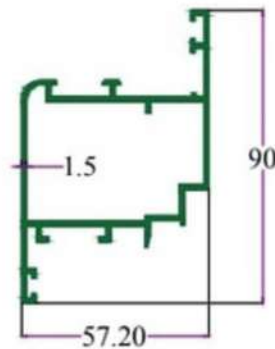

SEC. NO. 3940
WT. 4.400 TO 4.80 KG/12'

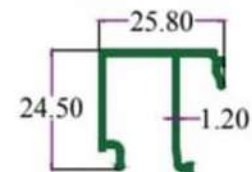

SEC. NO. 4770
WT. 1.030 TO 1.130 KG/12'

DOMAL / CASEMENT



INTELLIGENT
ALUMINIUM
itwalpanel.com

50MM CASEMENT SECTIONS

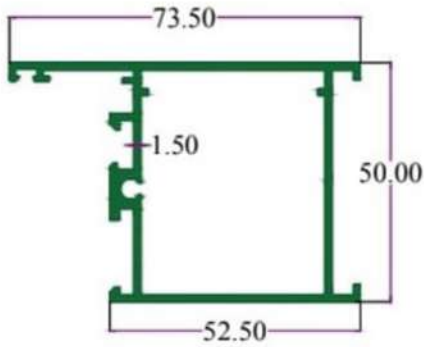

SEC.NO. 4771
WT. 3.320 TO 3.520 KG/12'

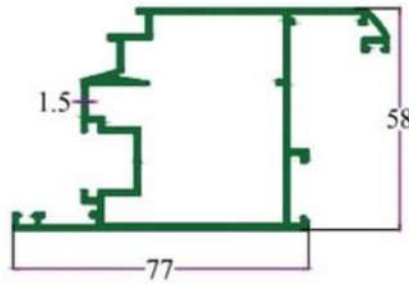

SEC.NO. 4774
WT. 5.150 TO 5.400 KG/12'

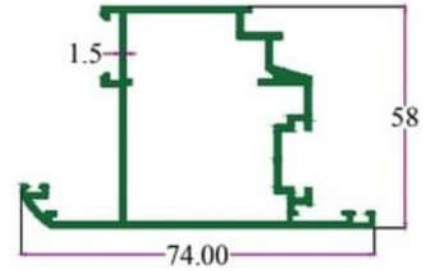

SEC.NO. 4775
WT. 3.320 TO 3.520 KG/12'

CURTAIN WALL



INTELLIGENT
ALUMINIUM
itowalpanel.com

STRUCTURE

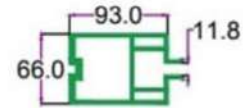

SEC. NO. 2425
WT. 13.100 TO 13500 KG/12'

S No.	Sec No.	A in mm.	B in mm.	C in mm.	D in mm.	T in mm.	Weight (KG/15')
1	2351	50.00	50.00	5.00	1.4	1.40	3.000 - 3.500
2	2352	50.00	50.00	5.00	1.5	1.50	3.700 - 4.300
3	2353	50.00	50.00	5.00	1.7	1.70	4.400 - 5.000
4	2354	50.00	50.00	5.00	3.0	3.00	7.000 - 7.400
5	2384	50.50	50.50	6.06	2.02	1.32	3.200 - 3.500
6	2355	63.00	63.00	5.00	5.0	2.40	7.700 - 8.500
7	2356	64.00	58.00	5.00	2.0	2.00	6.000 - 6.300
8	2357	64.00	58.00	10.0	5.0	1.40	4.700 - 5.200
9	2358	64.00	58.00	10.0	5.0	1.60	5.300 - 5.800
10	2359	64.00	58.00	10.0	5.0	1.80	6.000 - 6.500
11	2360	64.00	58.00	10.0	5.0	3.00	9.100 - 9.500
12	2361	81.00	50.00	6.00	1.6	1.60	5.000 - 5.500
13	2362	81.00	50.00	6.00	1.6	2.00	6.200 - 6.500
14	2363	81.00	50.00	6.00	1.8	1.80	6.000 - 6.500
15	2364	81.00	50.00	6.00	3.0	3.00	9.000 - 10.00
16	2365	81.00	50.00	12.0	1.6	1.30	4.700 - 5.200
17	2366	81.00	50.00	12.0	1.6	1.50	5.300 - 5.700
18	2367	81.00	50.00	12.0	1.8	1.80	6.000 - 6.500
19	2368	81.00	50.00	12.0	2.2	2.20	7.700 - 8.300
20	2369	81.00	50.00	12.0	3.0	3.00	9.600 - 10.00
21	2370	81.00	50.00	25.0	2.2	2.20	10.00 - 10.500
22	2371	81.00	50.00	25.0	3.0	3.00	11.00 - 11.500
23	2372	81.50	50.00	7.50	2.0	1.50	3.700 - 4.000(12')
24	2373	100.00	50.00	6.00	2.0	2.00	7.200 - 8.000
25	2374	100.00	50.00	6.00	3.0	3.00	10.500 - 11.000
26	2375	100.00	50.00	10.0	2.0	2.00	7.100 - 7.600
27	2376	100.00	50.00	10.0	3.0	3.00	10.800 - 11.600
28	2377	100.00	57.00	10.0	5.0	1.60	6.500 - 7.200
29	2378	100.00	57.00	10.0	5.0	2.50	9.600 - 10.600
30	2379	100.00	67.00	22.0	2.0	2.00	6.900 - 7.200(12')
31	2380	114.00	63.50	5.00	6.0	2.00	8.600 - 9.500
32	2381	114.00	63.50	5.00	6.0	2.50	10.500 - 11.500
33	2382	125.00	45.00	10.0	3.0	2.00	8.200 - 9.000

CURTAIN WALL



INTELLIGENT
ALUMINIUM
itowalpanel.com

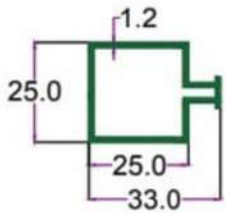

SEC. NO. 2511
WT. 1.330 TO 1.500 KG./12'

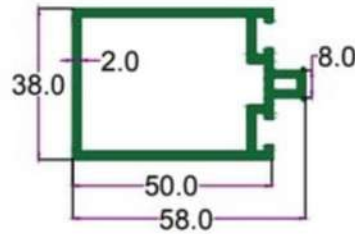

SEC. NO. 2509
WT. 3.000 TO 3.200 KG./12'

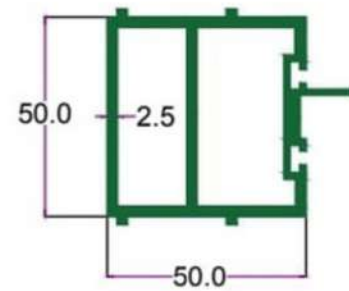

SEC. NO. 2510
WT. 6.260 TO 6.400 KG./12'

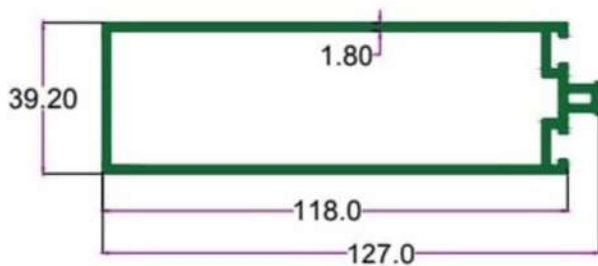

SEC. NO. 2508
WT. 6.530 TO 6.750 KG./12'

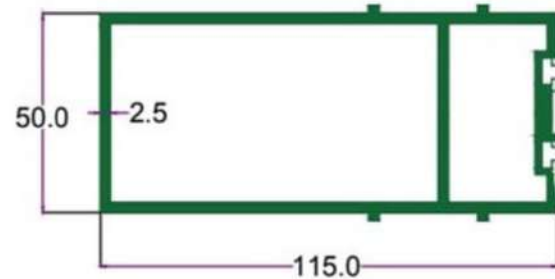

SEC. NO. 2512
WT. 9.370 TO 9.560 KG./12'

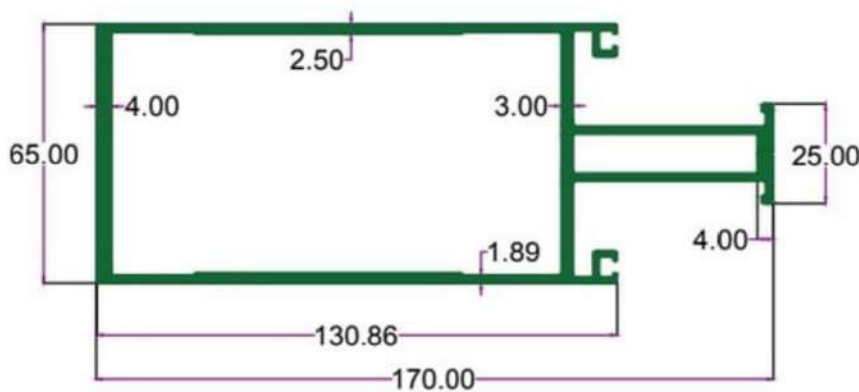

SEC. NO. 4592
WT. 12.950 TO 13.350 KG./ 12'

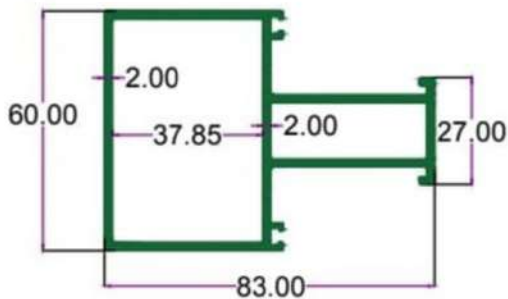

SEC. NO. 4859
WT. 6.200 TO 6.450 KG./ 12'

CURTAIN WALL



INTELLIGENT
ALUMINIUM
itowalpanel.com

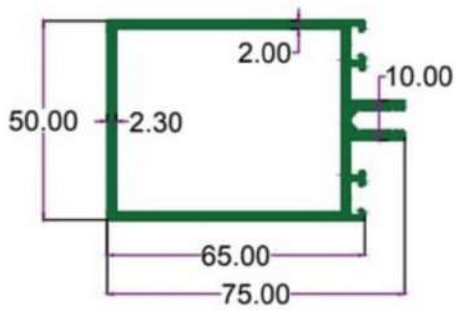

SEC.NO. 4864
WT. 5.500 TO 5.750 KG./ 12'

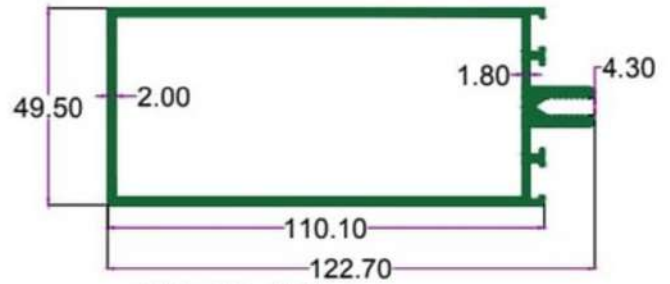

SEC. NO. 4161
WT. 7.150 TO 7.650 KG./ 12'

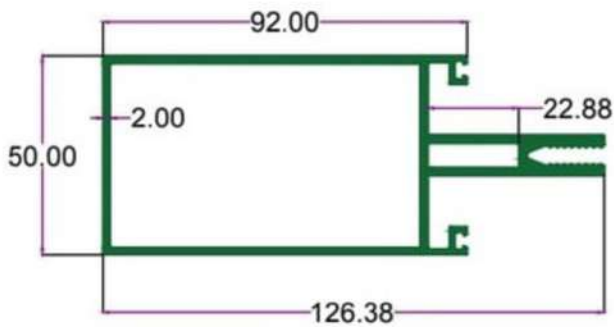

SEC. NO. 2461
WT.7.450 To 7.750 KG./15'

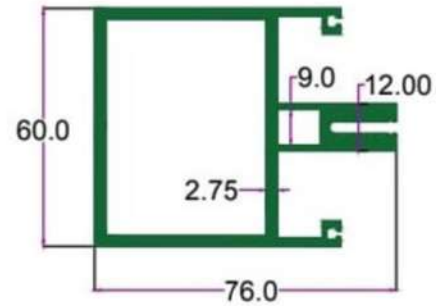

SEC. No. 2439
WT. 8.000 TO 8.500 KG./12'

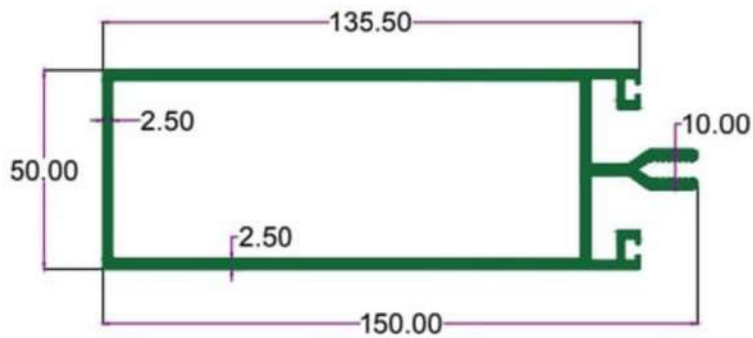

SEC. NO. 4160
WT. 10.400 TO 10.900 KG/12'

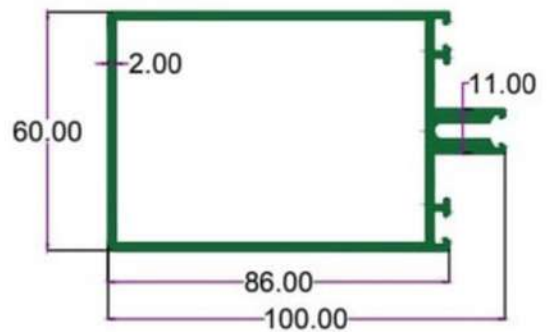

SEC.NO. 4359
WT. 6.500 TO 6.750 KG./ 12'

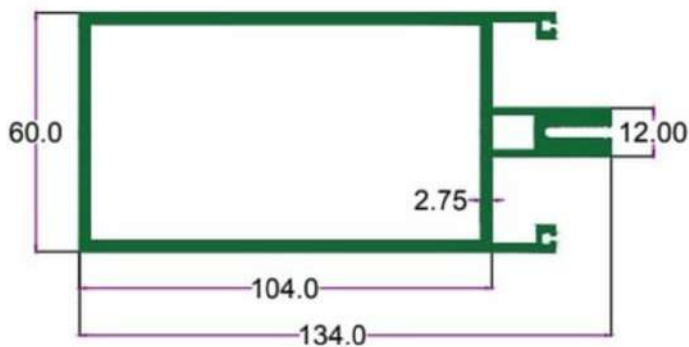

SEC. No. 2438
WT. 12.390 TO 12.600 KG/12'

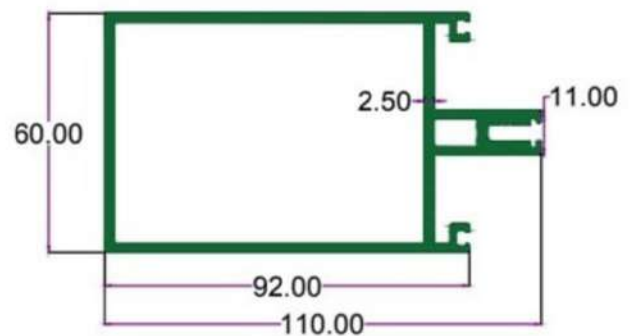

SEC.NO. 4372
WT. 9.270 TO 9.750 KG./ 12'

CURTAIN WALL



INTELLIGENT
ALUMINIUM
itowalpanel.com

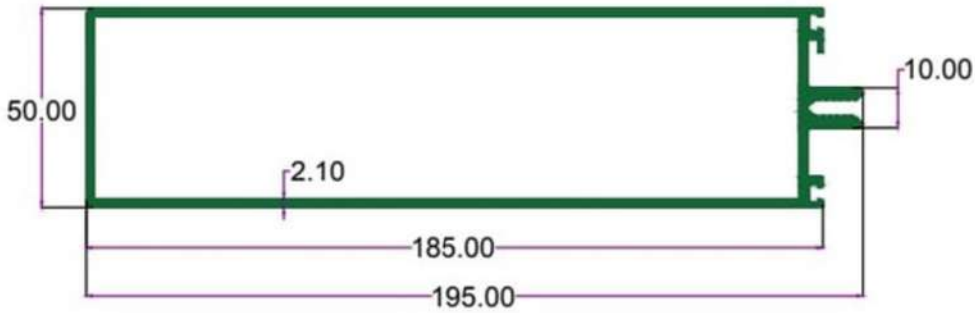

SEC.NO. 5031
WT. 10.650 TO 11.100 KG./ 12'

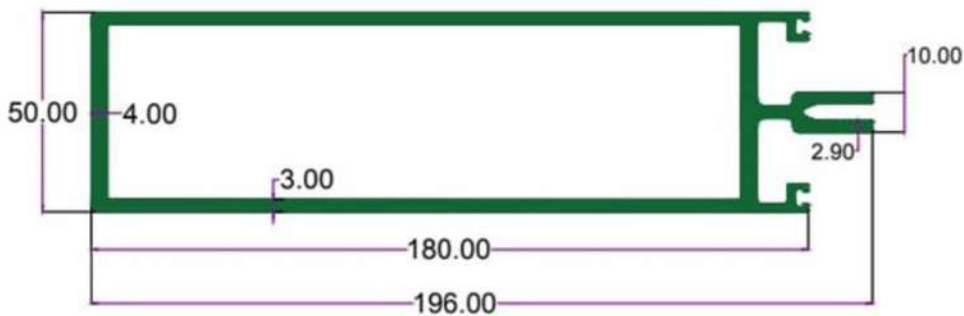

SEC.NO. 5032
WT. 15.730 TO 16.150 KG./ 12'

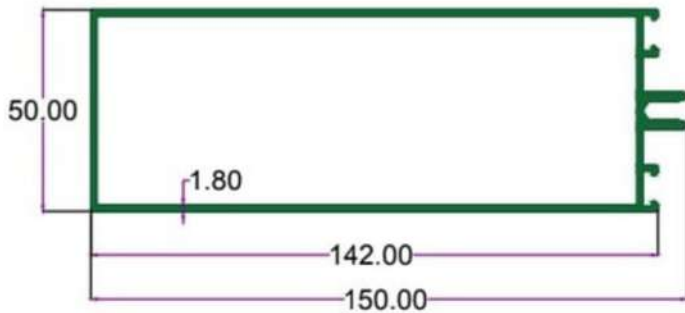

SEC. NO. 3831
WT. 7.500 TO 7.800 KG./12'

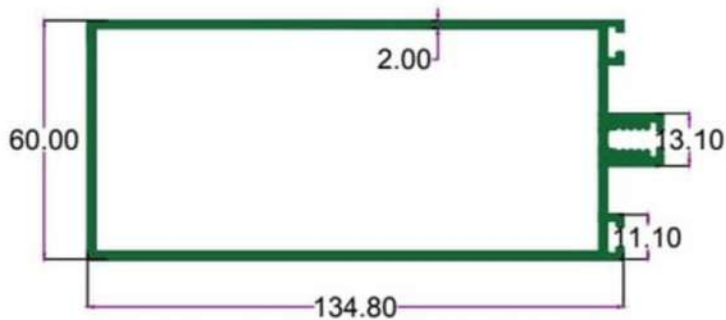

SEC.NO. 5054
WT. 8.720 TO 9.050 KG./ 12'

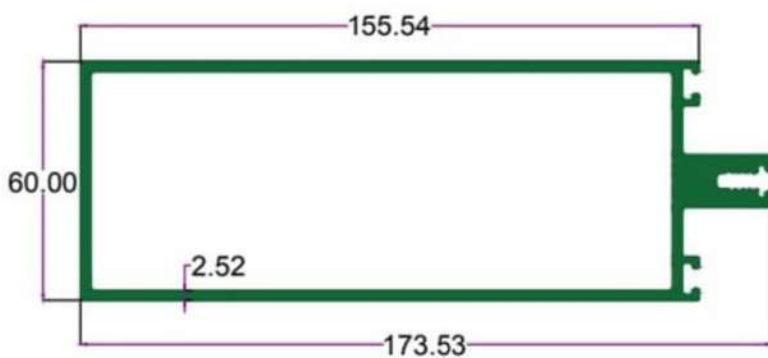

SEC. NO. 4119
WT. 11.820 TO 12.300 KG./ 12'

CURTAIN WALL



INTELLIGENT
ALUMINIUM
itwalpanel.com

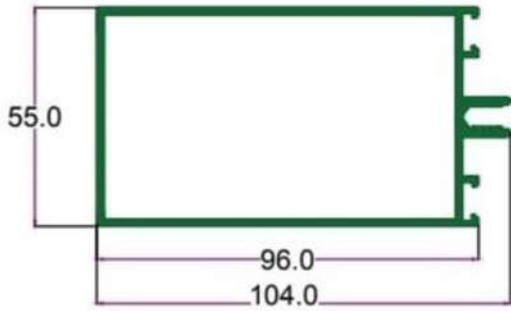

SEC. NO. 2430
(L) WT. 5.680 TO 5.850 KG/12'
(H) WT. 6.640 TO 6.850 KG/12'

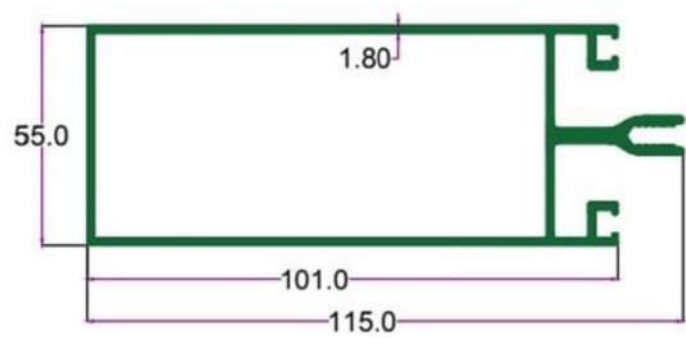

SEC. NO. 2431
WT. 8.400 TO 8.600 KG/12'

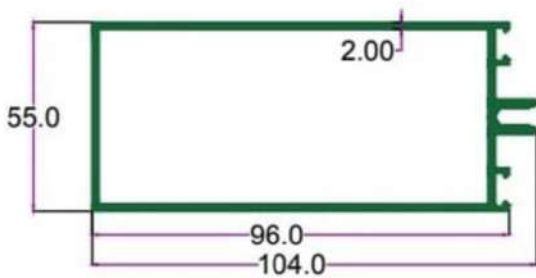

SEC. NO. 2433
WT. 8.080 TO 8.250 KG/12'

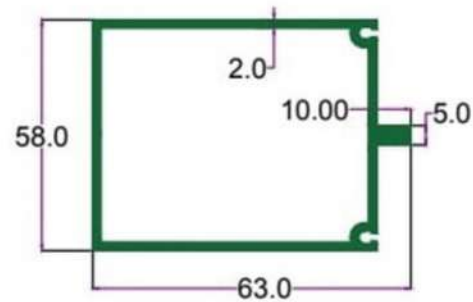

SEC. NO. 2434
WT. 6.500 TO 7.200 KG/15'



SEC. NO. 2432
WT. 4.800 TO 5.300 KG./ 12'

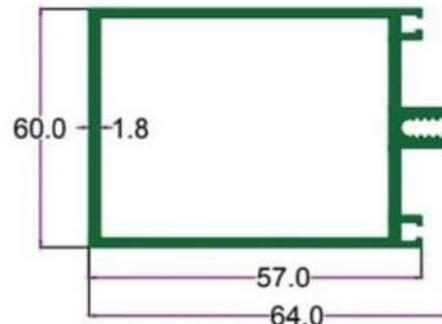

SEC. NO. 2435
WT. 6.800 TO 7.300 KG./15'

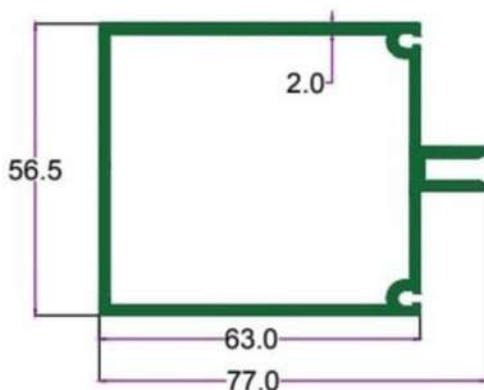

SEC. NO. 2436
WT. 7.000 TO 7.500 KG/15'

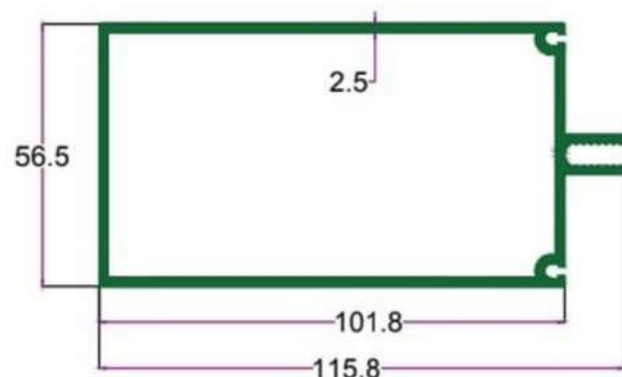

SEC. NO. 2437
WT. 10.850 TO 11.220 KG./15'

CURTAIN WALL



INTELLIGENT
ALUMINIUM
itowalpanel.com

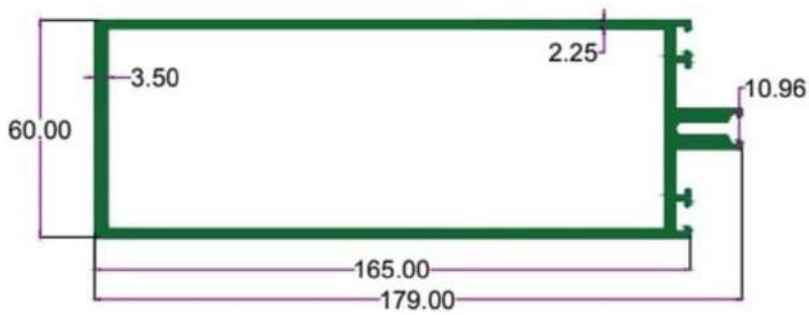

SEC.NO. 4358
WT. 12.150 TO 12.600 KG./ 12'

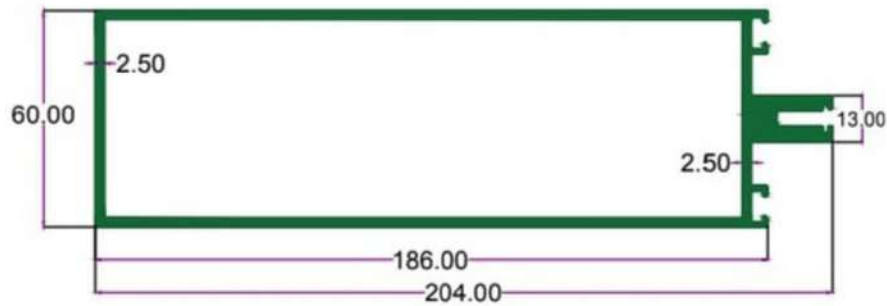

SEC.NO. 4371
WT. 14.220 TO 14.850 KG./ 12'

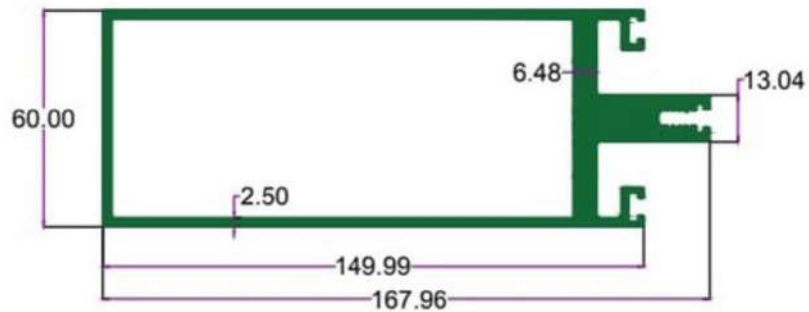

SEC. NO. 4120
WT. 16.100 TO 16.500 KG./ 12'

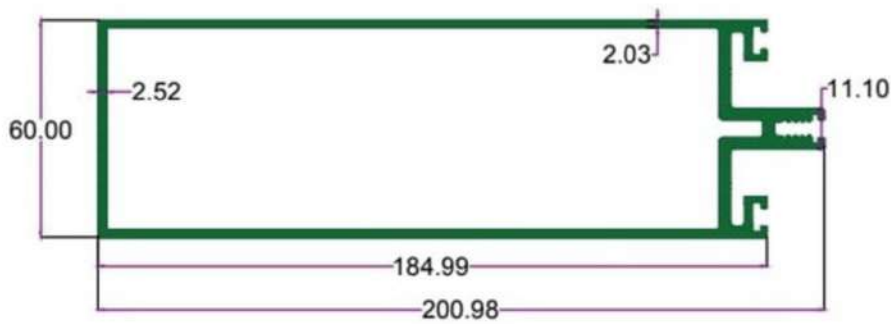

SEC.NO. 5045
WT. 12.600 TO 13.100 KG./ 12'

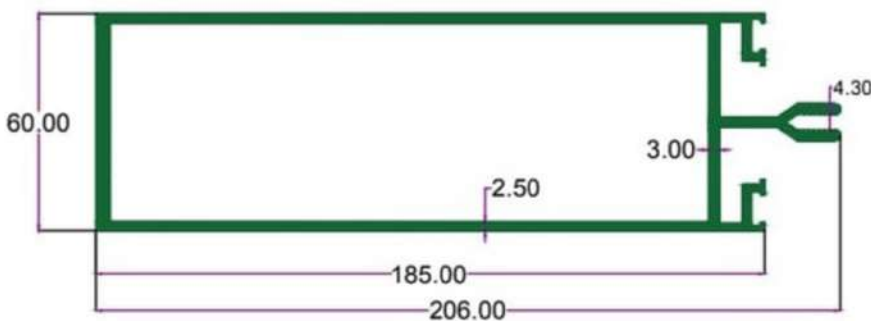

SEC. NO. 4187
WT. 14.850 TO 15.650 KG./ 12'

CURTAIN WALL



INTELLIGENT
ALUMINIUM
itwalpanel.com

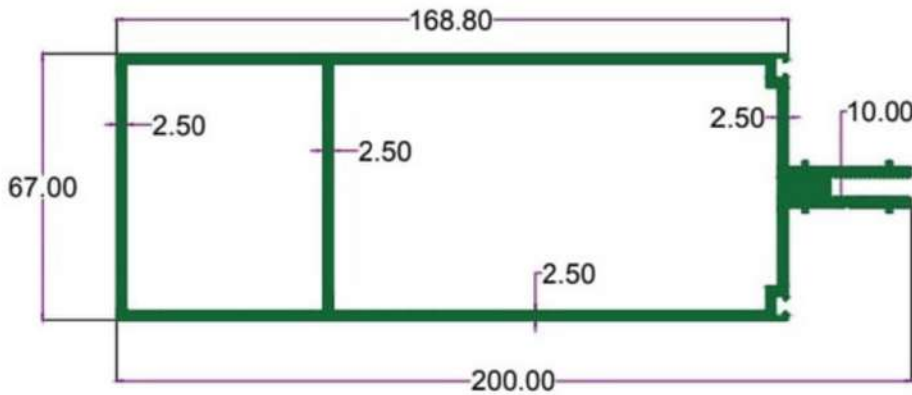

SEC. NO. 4137
WT. 17.300 TO 18.000 KG./ 12'

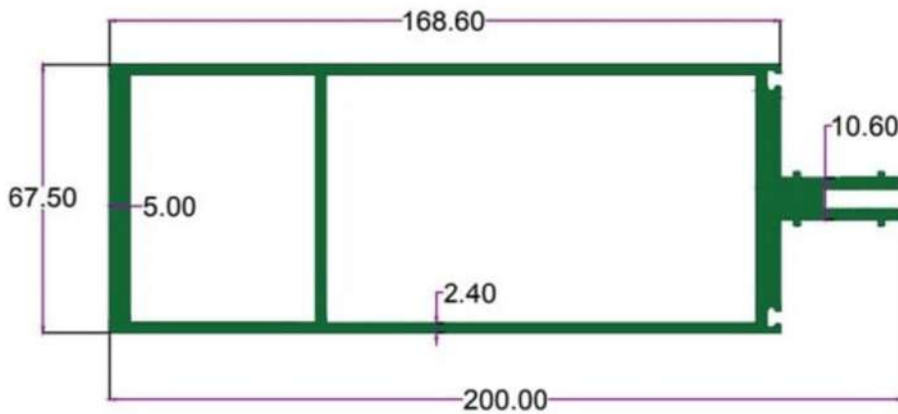

SEC. NO. 4138
WT. 15.200 TO 15.700 KG./ 12'

TRANSOM

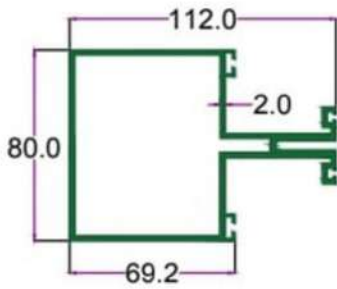

SEC. NO. 2455
WT. 11.300 TO 11.800 KG./ 15'

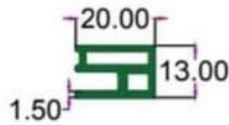

SEC. NO. 4360
WT. 1.200 TO 1.400 KG./ 12'

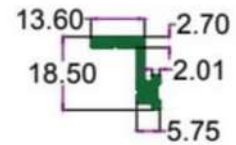

SEC. NO. 4594
WT. 0.860 TO 1.000 KG./ 12'

CURTAIN WALL



INTELLIGENT
ALUMINIUM
itwalpanel.com

PRESSURE PLATE

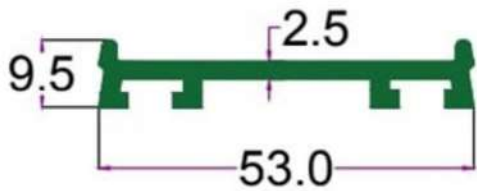

SEC. NO. 2426
WT. 2.300 TO 2.550 KG./ 15'

PRESSURE PLATE

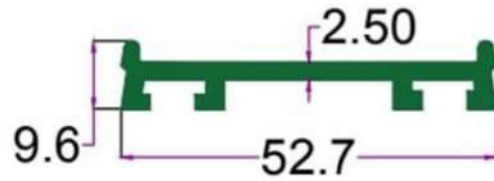

SEC. NO. 2427
WT. 2.700 TO 2.900 KG./ 15'

COVER PLATE

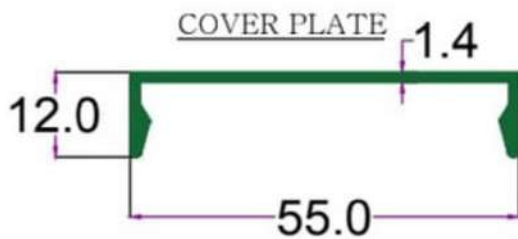

SEC. NO. 2428
WT. 1.200 TO 1.400 KG./ 12'

COVER PLATE

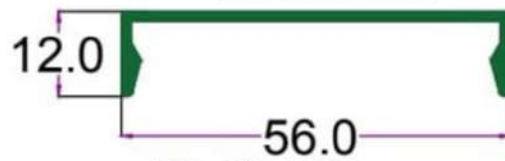

SEC. NO. 2429
WT. 1.650 TO 1.850 KG./ 15'

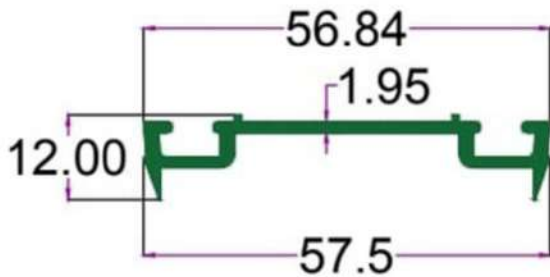

SEC. No. 2440
WT. 1.400 TO 1.600 KG/12'

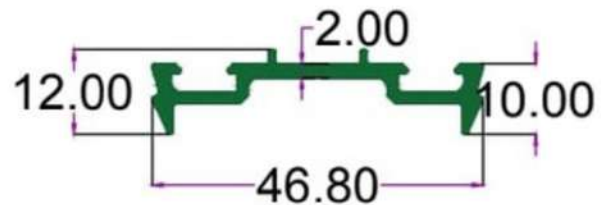

SEC. NO. 5028
WT. 1.330 TO 1.550 KG./ 12'



SEC. NO. 5029
WT. 1.370 TO 1.550 KG./ 12'

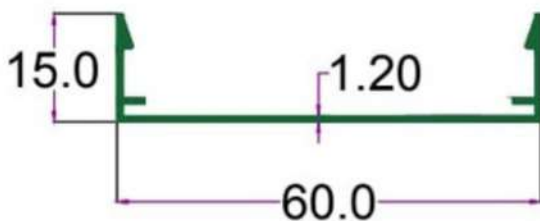

SEC. No. 2441
WT. 0.800 TO 0.900 KG/12'

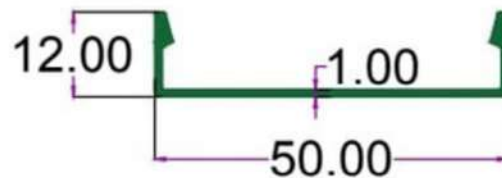

SEC. NO. 5030
WT. 0.800 TO 0.900 KG./ 12'

CURTAIN WALL



INTELLIGENT
ALUMINIUM
itowalpanel.com

S.G.Z. BIG TAG

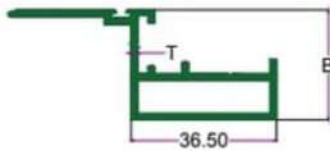

S No.	SECTION No.	A IN MM.	B IN MM.	T IN MM.	WEIGHT (KG/15')
1	2446 A	67.10	27.50	1.40	2.600-2.900
2	2446 B	67.10	27.50	1.65	3.100-3.300
3	2446 C	67.10	27.50	1.90	3.400-3.650

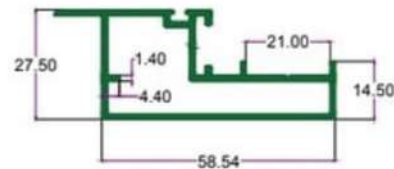

SEC. NO. 4142/D-6383
WT. 2.780 TO 3.00 KG./ 12'

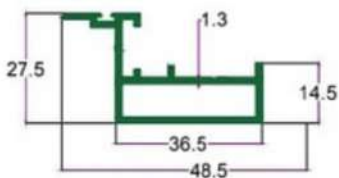

SEC. NO. 2448
WT. 2.370 TO 2.550 KG/ 15'

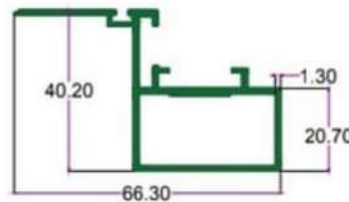

SEC. NO. 4196
WT. 2.450 TO 2.650 KG./ 12'

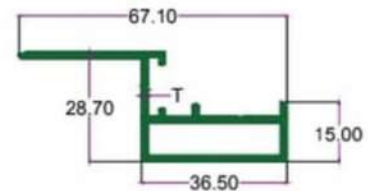

SEC. NO. 2457
WT. 1.960 TO 2.250 KG/15'

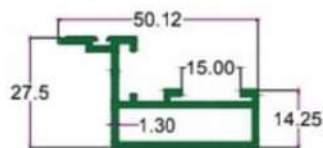

SEC. NO. 2448A
(L) WT. 2.820 TO 3.000 KG/15'
(H) WT. 3.120 TO 3.250 KG/15'

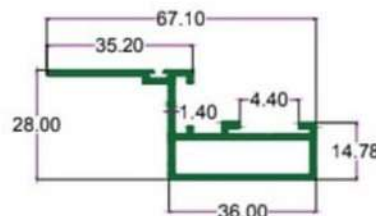

SEC. NO. 2456
WT. 2.340 TO 2.550 KG/15'

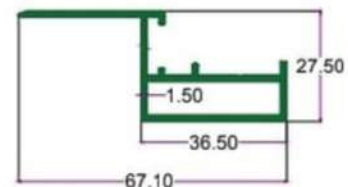

SEC. NO. 2460
WT. 2.700 TO 2.900 KG./ 15'

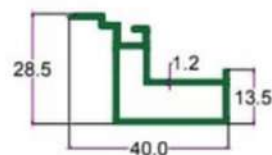

SEC. NO. 3201
WT. 1.680 TO 1.900 KG/15'

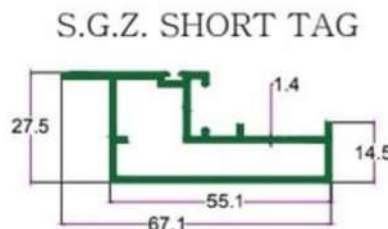

SEC. NO. 2450
(L) WT. 3.230 TO 3.400 KG/15'
(H) WT. 4.120 TO 4.250 KG/15'

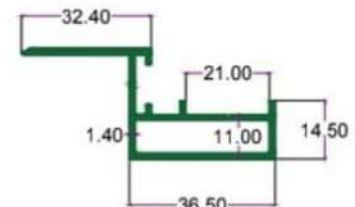

SEC. NO. 4141/D-6859
WT. 2.040 TO 2.200 KG./ 12'

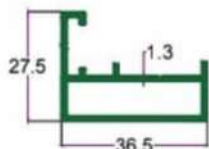

SEC. NO. 2449 ,
(L) WT. 1.990 TO 2.100 KG/15'
(H) WT. 3.120 TO 3.300 KG/15'

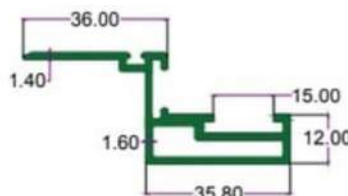

SEC. NO. 4140/D-4629
WT. 2.370 TO 2.560 KG./ 12'

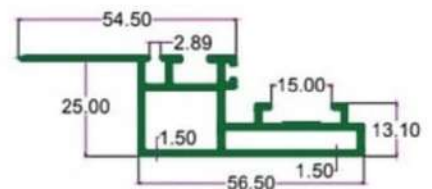

SEC. NO. 4593
WT. 3.280 TO 3.450 KG./ 12'

S.G.Z. SHORT TAG

WINDOW MESH



INTELLIGENT
ALUMINIUM
itowalpanel.com

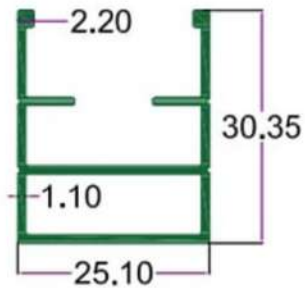

SEC.NO. 4776
WT. 1.290 TO 1.400 KG./ 12'

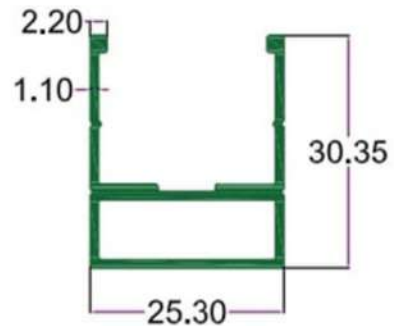

SEC.NO. 4777
WT. 1.340 TO 1.450 KG./ 12'

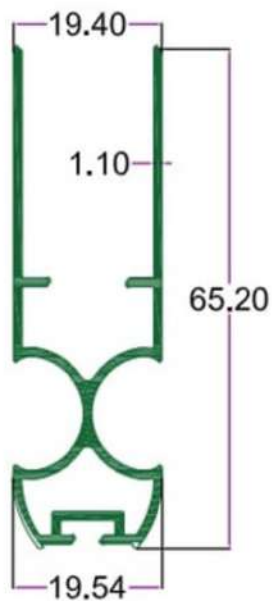

SEC.NO. 4778
WT. 2.000 TO 2.150 KG./ 12'

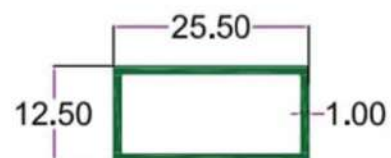

SEC.NO. 4779
WT. 0.700 TO 0.800 KG./ 12'

WINDOW MESH



INTELLIGENT
ALUMINIUM
itw@alpanel.com

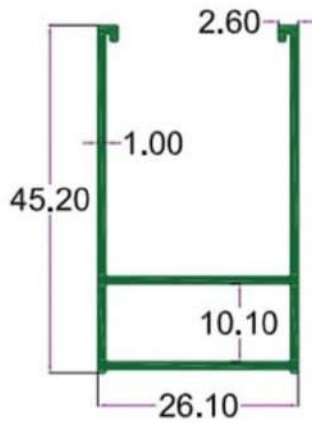

SEC.NO. 4431
WT. 1.400 TO 1.600 KG/12'

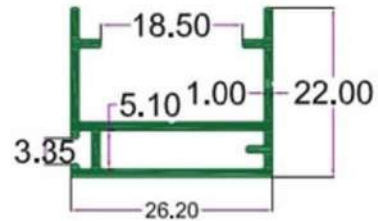

SEC.NO. 4433
WT. 1.000 TO 1.200 KG/12'

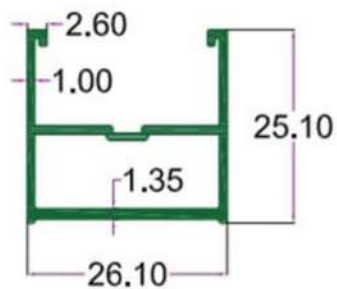

SEC.NO. 4432
WT. 1.100 TO 1.300 KG/12'

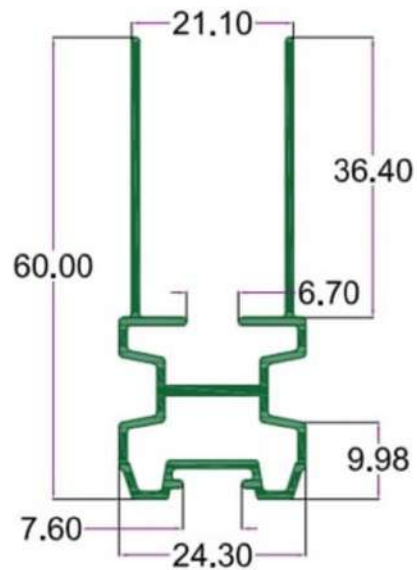

SEC.NO. 4434
WT. 1.930 TO 2.1500 KG/12'

WINDOW MESH



INTELLIGENT
ALUMINIUM
itwalpanel.com

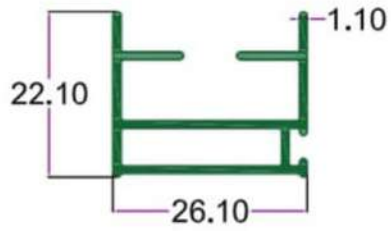

SEC.NO. 5106
WT. 1.130 TO 1.380 KG/12'



INTELLIGENT
ALUMINIUM

2024



INTELLIGENT
ALUMINIUM

itswallpanel.com



CONTACT US

 +91 9205080482

 www.itswallpanel.com

 hello@itswallpanel.com

 Ghaziabad , India