

DOOR SECTION

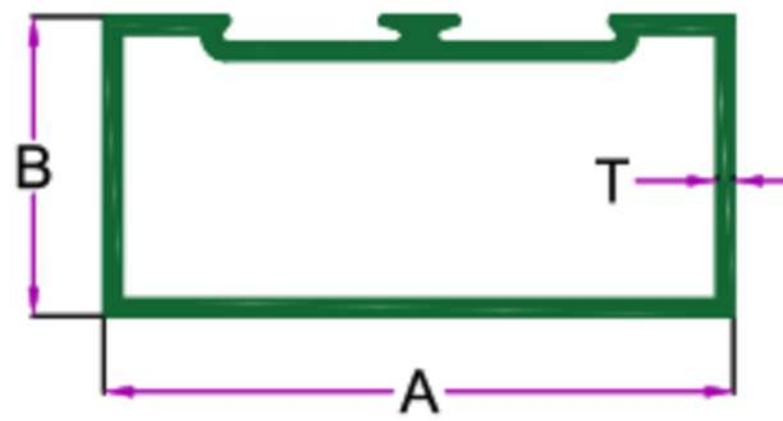

INTELLIGENT
ALUMINIUM
itswallpanel.com



SINGLE PARTITION

S.No.	Section No.	A IN mm.	B IN mm.	T IN mm.	Weight (KG/15')
1	1501	50.00	25.00	1.00	2.200-2.500
2	1502	50.00	25.00	1.55	2.800-3.200
3	1503	63.00	37.00	1.10	2.800-3.000
4	1504	63.00	37.00	1.20	3.100-3.300
5	1505	63.00	37.00	1.30	3.400-3.600
6	1506	63.00	37.00	1.50	3.800-4.200
7	1507	63.00	37.00	1.85	4.600-5.000
8	1508	63.00	37.00	2.10	5.200-5.500
9	1509	63.00	37.00	2.40	6.000-6.300
10	1510	63.00	37.00	3.18	6.900-7.500
11	1511	63.00	37.00	4.00	8.560-9.360
12	1512	63.00	38.00	1.00	2.700-2.750
13	1513	63.50	35.00	1.55	3.600-4.000
14	1535	63.50	38.10	0.95	2.500-2.700
15	1536	63.50	38.10	1.00	2.700-2.900
16	1514	83.00	25.40	1.50	3.900-4.400
17	1515	83.00	38.00	1.30	4.000-4.600
18	1516	83.00	38.00	1.50	4.700-5.200
19	1517	83.00	38.00	2.10	6.000-6.500
20	1518	94.7	42.50	1.30	4.400-4.800
21	1519	101.00	25.00	1.10	4.000-4.300
22	1520	101.00	25.00	1.55	4.800-5.200
23	1521	101.00	44.00	1.30	4.700-5.300
24	1522	101.00	44.00	1.50	5.400-5.600
25	1523	101.00	44.00	1.60	5.800-6.300
26	1524	101.00	44.00	1.90	6.600-7.200
27	1525	101.00	44.00	2.10	7.500-8.000
28	1526	101.00	44.00	2.80	9.800-10.300
29	1527	101.00	44.00	3.18	10.500-11.500
30	1528	101.00	44.00	4.00	12.800-13.800
31	1529	101.00	45.00	2.50	8.800-9.200
32	1530	125.00	44.00	1.40	6.000-6.600
33	1537	125.00	44.00	2.00	8.000-8.500
34	1531	125.00	44.00	3.00	12.500-13.000
35	1532	100.00	20.00	4.00	11.500-11.900
36	1533	150.00	44.45	2.00	9.600-10.000
37	1534	150.00	44.45	2.98	14.100-11.700

DOOR SECTION



INTELLIGENT
ALUMINIUM
itswallpanel.com

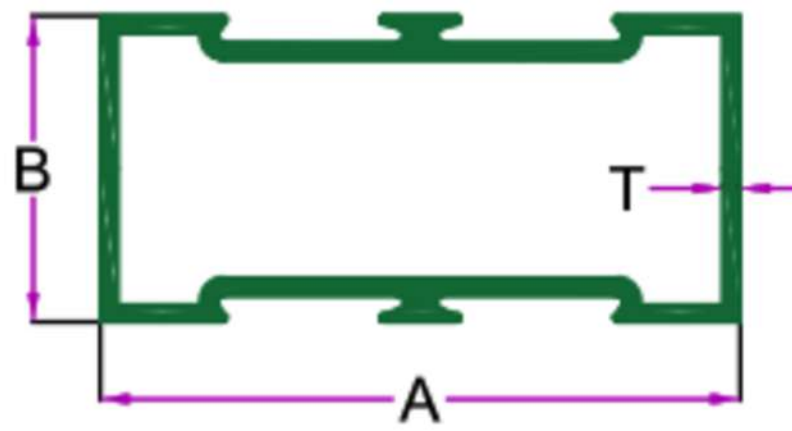

DOUBLE PARTITION

S.No.	Section No.	A IN mm.	B IN mm.	T IN mm.	Weight (KG/15')
1	1551	50.00	25.00	0.95	2.200-2.500
2	1552	50.00	25.00	1.30	2.500-3.100
3	1553	63.00	37.00	1.00	2.800-3.000
4	1554	63.00	37.00	1.10	3.100-3.300
5	1555	63.00	37.00	1.25	3.400-3.600
6	1556	63.00	37.00	1.45	3.800-4.200
7	1557	63.00	37.00	1.75	4.600-5.000
8	1558	63.00	37.00	2.00	5.200-5.500
9	1559	63.00	37.00	2.30	6.000-6.300
10	1560	63.00	37.00	3.18	6.800-7.200
11	1561	63.00	37.00	4.00	8.500-9.300
12	1562	63.00	38.00	0.90	2.711-2.750
13	1584	63.50	38.10	0.85	2.500-2.700
14	1585	63.50	38.10	0.90	2.700-2.900
15	1563	83.00	25.40	1.50	4.100-4.400
16	1564	83.00	38.00	1.20	4.000-4.500
17	1565	83.00	38.00	1.65	5.100-5.500
18	1566	83.00	38.00	2.10	6.000-6.500
19	1567	101.00	25.00	1.10	4.000-4.300
20	1568	101.00	25.00	1.55	5.000-5.400
21	1569	101.00	44.00	1.30	4.700-5.300
22	1570	101.00	44.00	1.40	5.400-5.600
23	1571	101.00	44.00	1.55	5.800-6.300
24	1572	101.00	44.00	1.80	6.600-7.200
25	1573	101.00	44.00	2.05	7.500-8.000
26	1574	101.00	44.00	2.40	8.800-9.200
27	1575	101.00	44.00	2.50	9.200-9.500
28	1576	101.00	44.00	3.18	10.500-11.500
29	1577	101.00	44.00	4.00	12.700-13.900
30	1578	125.00	44.00	1.30	6.000-6.600
31	1579	125.00	44.00	3.00	12.500-13.000
32	1580	101.00	45.50	3.00	10.500-11.500
33	1581	63.50	35.00	1.55	3.600-4.000
34	1582	150.00	44.45	2.00	7.900-8.200
35	1583	150.00	44.45	2.99	11.600-11.900

DOOR SECTION



INTELLIGENT
ALUMINIUM
itswallpanel.com

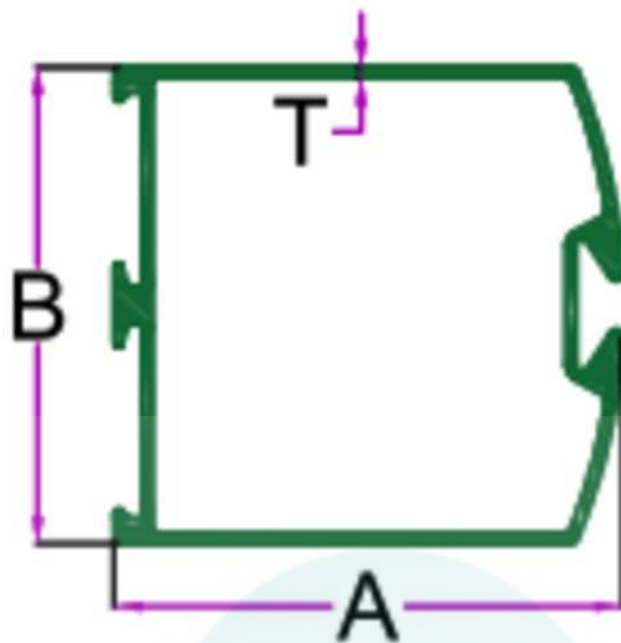

DOOR VERTICAL

S.No.	Section No.	A IN mm.	B IN mm.	T IN mm.	Weight (KG/15')
1	1601	47.00	44.00	1.10	2.600-2.900
2	1602	47.00	44.00	1.25	3.000-3.300
3	1603	47.00	44.00	1.40	3.400-3.600
4	1604	47.00	44.00	1.60	3.800-4.100
5	1605	47.00	44.00	1.95	4.400-4.800
6	1606	47.00	44.00	2.50	5.200-5.800
7	1607	47.00	44.00	3.18	6.800-7.000
8	1608	83.00	44.00	1.40	4.500-5.000
9	1609	83.00	44.00	1.60	5.100-5.800
10	1610	83.00	44.00	2.05	6.600-7.000
11	1611	83.00	44.00	2.50	7.500-8.000
12	1612	83.00	44.00	3.18	9.000-9.500
13	1613	83.00	44.00	3.50	9.700-10.200

itswallpanel.com

DOOR SECTION



INTELLIGENT
ALUMINIUM
itswallpanel.com

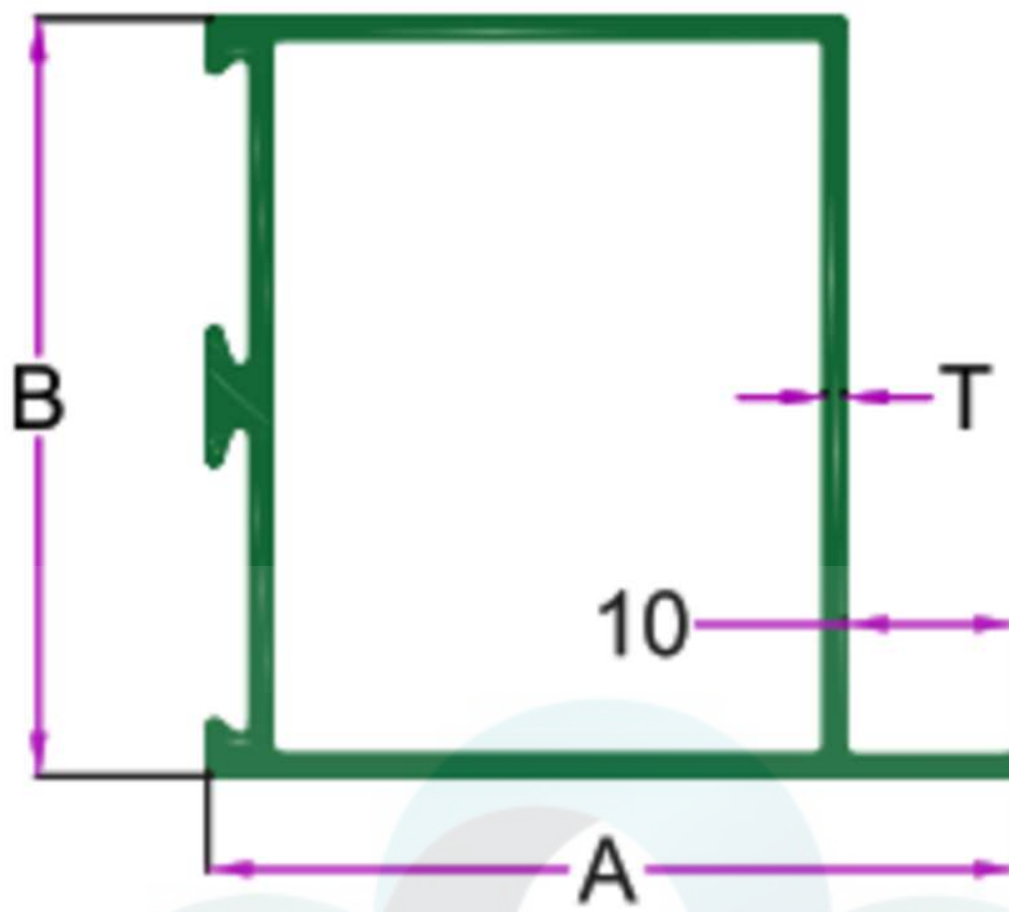

DOOR TOP SINGLE LEG

S.No.	Section No.	A IN mm.	B IN mm.	T IN mm.	Weight (KG/15')
1	1648	47.00	42.00	3.00	4.500-5.200
2	1649	47.00	44.00	1.05	2.800-3.000
3	1650	47.00	44.00	1.30	3.500-3.800
4	1651	47.00	44.00	1.50	4.000-4.300
5	1652	47.00	44.00	2.00	4.500-5.200
6	1653	47.00	44.00	3.18	6.000-6.500
7	1654	47.00	44.00	3.50	6.686-7.200
8	1620	73.00	36.00	1.39	3.750-4.000
9	1646	73.00	38.00	2.50	4.100-4.300
10	1647	73.00	38.00	3.40	5.100-5.300
11	1655	75.00	44.45	3.00	8.100-8.400
12	1656	83.00	44.00	1.75	5.100-6.400
13	1657	83.00	44.00	3.00	9.000-9.400
14	1658	83.00	44.00	3.50	9.700-10.500

DOOR SECTION



INTELLIGENT
ALUMINIUM
itswallpanel.com

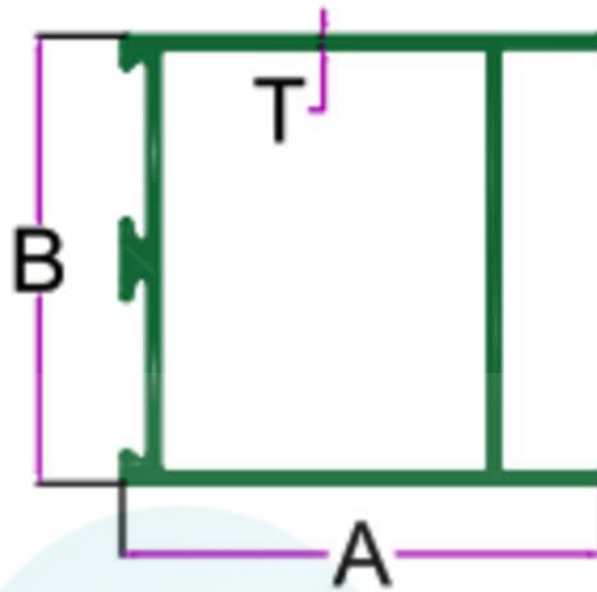

DOOR TOP DOUBLE LEG

S.No.	Section No.	A IN mm.	B IN mm.	T IN mm.	Weight (KG/15')
1	1621	47.00	42.00	3.00	5.240-5.500
2	1622	47.00	44.00	1.20	3.000-3.300
3	1623	47.00	44.00	1.60	3.400-3.600
4	1624	47.00	44.00	1.80	3.800-4.100
5	1625	47.00	44.00	2.00	4.400-5.000
6	1626	47.00	44.00	2.20	5.500-6.000
7	1627	47.00	44.00	3.18	6.800-7.400
8	1628	47.00	44.00	3.50	7.200-7.900
9	1629	83.00	44.00	1.50	4.800-5.200
10	1630	83.00	44.00	1.80	5.800-6.200
11	1631	83.00	44.00	2.50	6.800-7.500
12	1632	83.00	44.00	3.18	8.000-9.000
13	1633	83.00	44.00	3.50	9.100-10.000
14	4474	101.00	44.50	1.70	5.000-5.350
15	1634	114.00	44.00	1.30	4.900-5.300
16	1635	114.00	44.00	1.40	5.400-5.800
17	1636	114.00	44.00	1.70	6.500-7.200
18	1637	114.00	44.00	2.00	7.400-8.000
19	1638	114.00	44.00	2.50	9.000-10.000
20	1639	114.00	44.00	3.18	11.000-11.500
21	1640	114.00	44.00	3.50	12.74-13.740
22	1641	150.00	44.44	2.00	7.600-7.950
23	1642	150.00	44.44	3.00	11.200-11.500

DOOR SECTION



INTELLIGENT
ALUMINIUM
itswallpanel.com

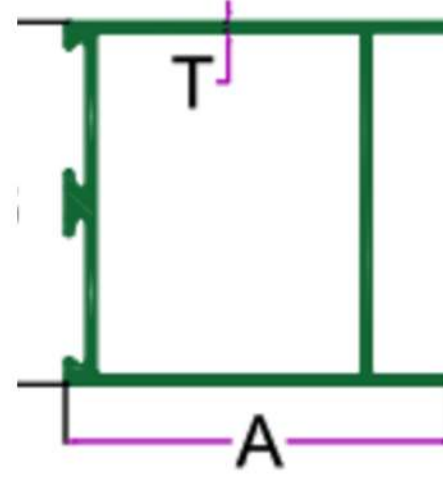
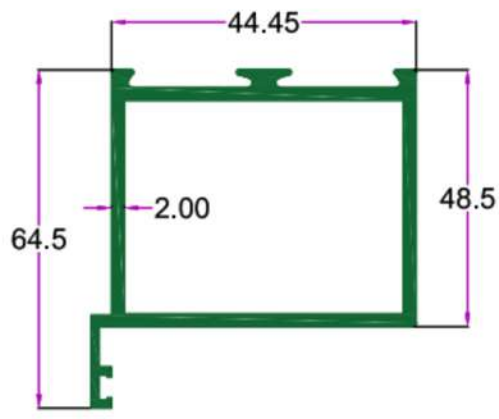

SEC. NO. 1660
WT. 5.300 TO 5.800 KG/15'

DOOR TOP DOUBLE LEG

S.No.	Section No.	A IN mm.	B IN mm.	T IN mm.	Weight (KG/15')
1	1621	47.00	42.00	3.00	5.240-5.500
2	1622	47.00	44.00	1.20	3.000-3.300
3	1623	47.00	44.00	1.60	3.400-3.600
4	1624	47.00	44.00	1.80	3.800-4.100
5	1625	47.00	44.00	2.00	4.400-5.000
6	1626	47.00	44.00	2.20	5.500-6.000
7	1627	47.00	44.00	3.18	6.800-7.400
8	1628	47.00	44.00	3.50	7.200-7.900
9	1629	83.00	44.00	1.50	4.800-5.200
10	1630	83.00	44.00	1.80	5.800-6.200
11	1631	83.00	44.00	2.50	6.800-7.500
12	1632	83.00	44.00	3.18	8.000-9.000
13	1633	83.00	44.00	3.50	9.100-10.000
14	4474	101.00	44.50	1.70	5.000-5.350
15	1634	114.00	44.00	1.30	4.900-5.300
16	1635	114.00	44.00	1.40	5.400-5.800
17	1636	114.00	44.00	1.70	6.500-7.200
18	1637	114.00	44.00	2.00	7.400-8.000
19	1638	114.00	44.00	2.50	9.000-10.000
20	1639	114.00	44.00	3.18	11.000-11.500
21	1640	114.00	44.00	3.50	12.74-13.740
22	1641	150.00	44.44	2.00	7.600-7.950
23	1642	150.00	44.44	3.00	11.200-11.500

DOOR SECTION



INTELLIGENT
ALUMINIUM
itswallpanel.com

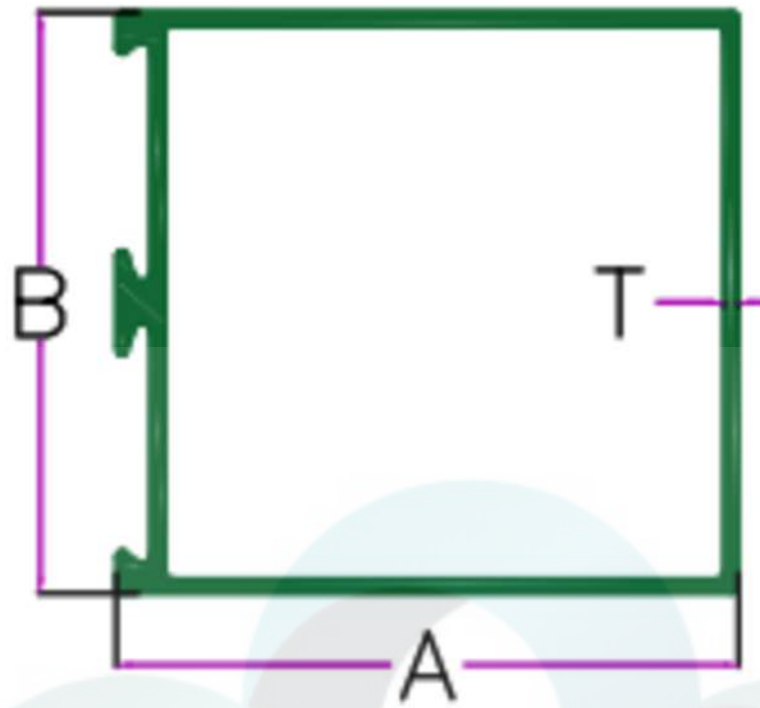

DOOR MIDDLE SINGLE

S.No.	Section No.	A IN mm.	B IN mm.	T IN mm.	Weight (KG/15')
1	1661	47.00	42.00	3.00	5.000-5.500
2	1662	47.00	44.00	1.10	2.700-2.900
3	1663	47.00	44.00	1.25	2.900 -3.100
4	1664	47.00	44.00	1.50	3.400-3.600
5	1665	47.00	44.00	1.70	3.700 -4.100
6	1666	47.00	44.00	2.10	4.500-5.000
7	1667	47.00	44.00	2.50	5.500-6.500
8	1668	47.00	44.00	3.18	6.800-7.000
9	1669	47.00	44.00	3.50	7.100 -7.600
10	1670	83.00	44.00	1.55	4.800 -5.100
11	1671	83.00	44.00	1.80	5.600-6.000
12	1672	83.00	44.00	2.15	6.500-7.000
13	1673	83.00	44.00	2.80	8.000-9.000
14	1674	83.00	44.00	3.18	9.500-10.500
15	1675	83.00	44.00	3.50	10.500-11.000
16	1676	102.00	44.00	3.00	8.690-9.000

DOOR SECTION



INTELLIGENT
ALUMINIUM
itswallpanel.com

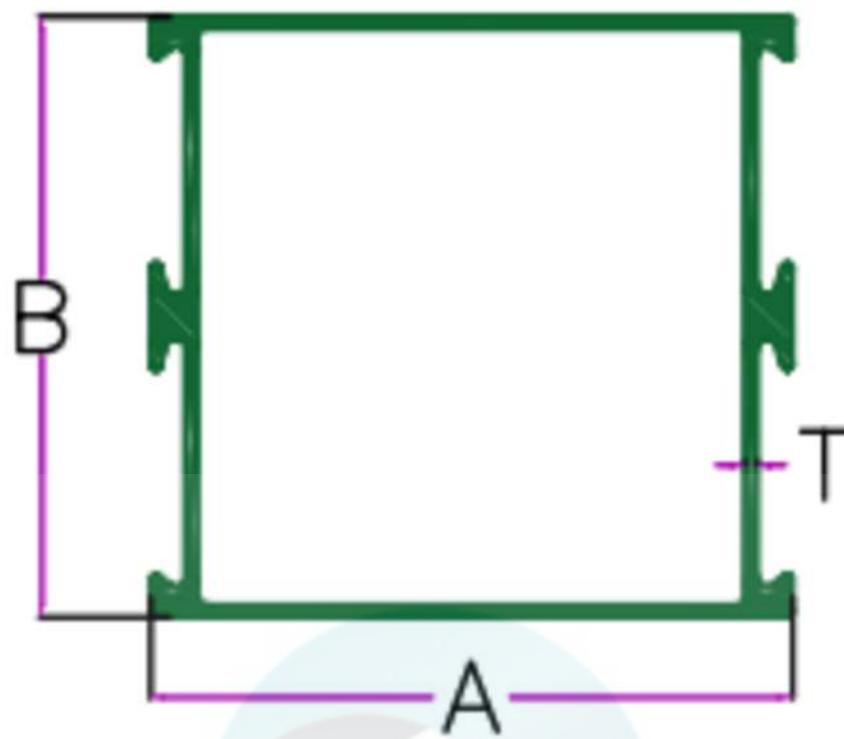

DOOR MIDDLE DOUBLE

S.No.	Section No.	A IN mm.	B IN mm.	T IN mm.	Weight (KG/15')
1	1681	47.00	44.00	1.00	2.600-2.900
2	1682	47.00	44.00	1.25	2.900-3.100
3	1683	47.00	44.00	1.50	3.400-3.600
4	1684	47.00	44.00	1.70	3.700-4.100
5	1685	47.00	44.00	2.10	4.400-4.800
6	1686	47.00	44.00	2.40	5.500-6.000
7	1687	47.00	44.00	3.18	6.800-7.500
8	1688	47.00	44.00	3.50	7.200-7.800
9	1689	83.00	44.00	1.40	4.850-5.100
10	1690	83.00	44.00	1.60	5.400-5.800
11	1691	83.00	44.00	1.70	5.600-6.400
12	1692	83.00	44.00	2.15	6.800-7.000
13	1693	83.00	44.00	2.80	8.000-9.300
14	1694	83.00	44.00	3.18	9.400-10.400
15	1695	83.00	44.00	3.50	10.100-11.000
16	1696	100.00	44.00	2.00	7.200-7.600
17	4473	101.00	44.45	1.65	5.000-5.350
18	1697	150.00	44.45	2.00	9.700-10.00
19	1698	150.00	44.45	2.99	14.100-15.00

DOOR SECTION



INTELLIGENT
ALUMINIUM
itswallpanel.com

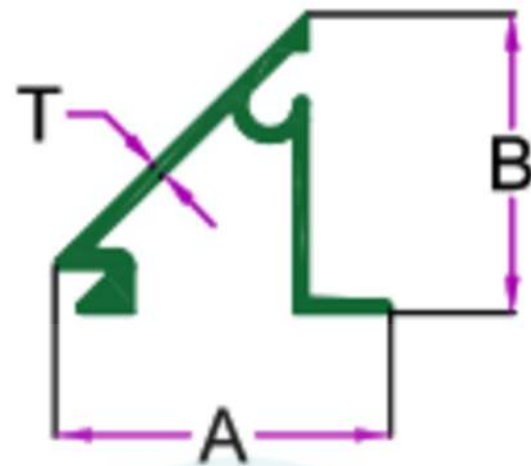

GLAZING CLIP

S.No.	Section No.	A IN mm.	B IN mm.	T IN mm.	Weight (KG/15')
1	1750	18.5	16.8	0.50	0.250-0.270
2	1751	18.5	16.8	0.60	0.280-0.300
3	1752	18.5	16.8	0.65	0.300-0.325
4	1753	18.5	16.8	0.70	0.400-0.450

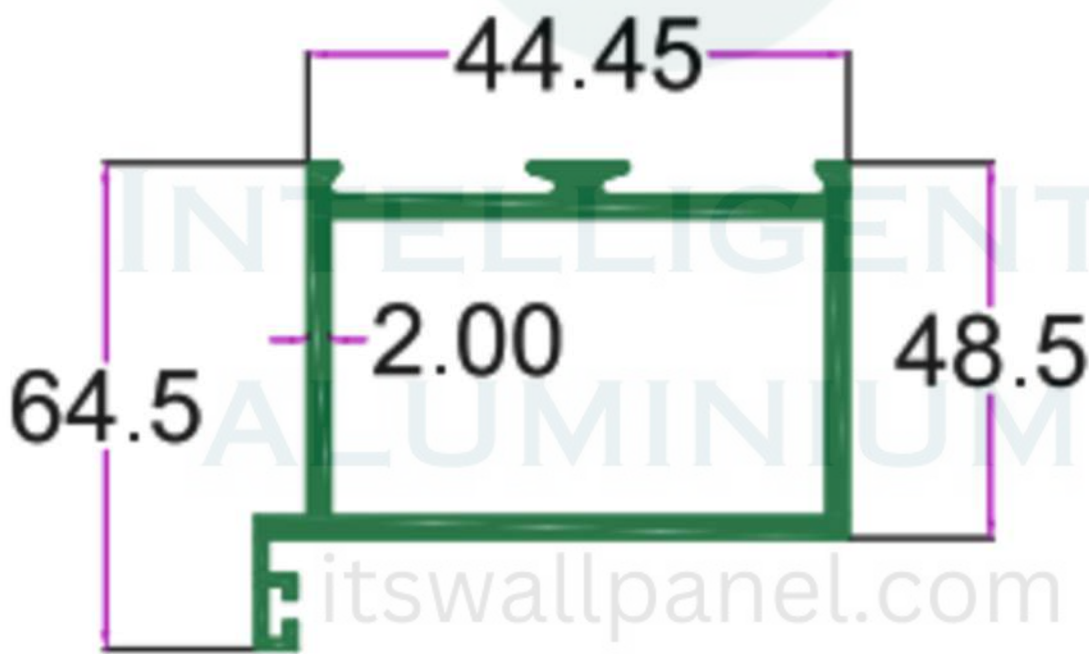

SEC. NO. 1600

WT. 5.30 TO 5.80 KG/15'

DOOR SECTION



INTELLIGENT ALUMINIUM
itswallpanel.com

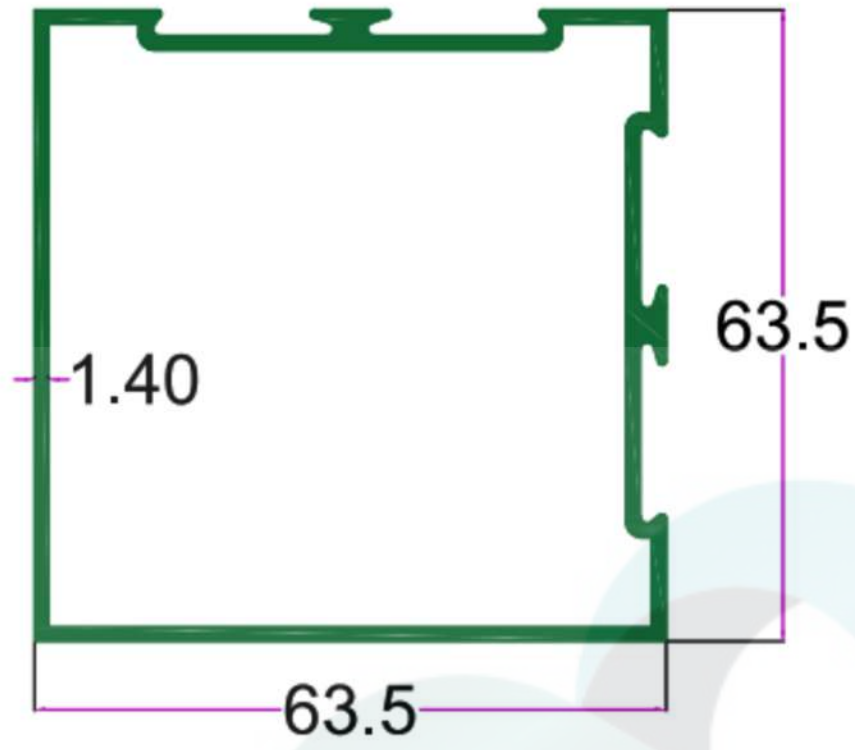

SEC.No. 1757
WT. 4.00 TO 5.00 KG/15'

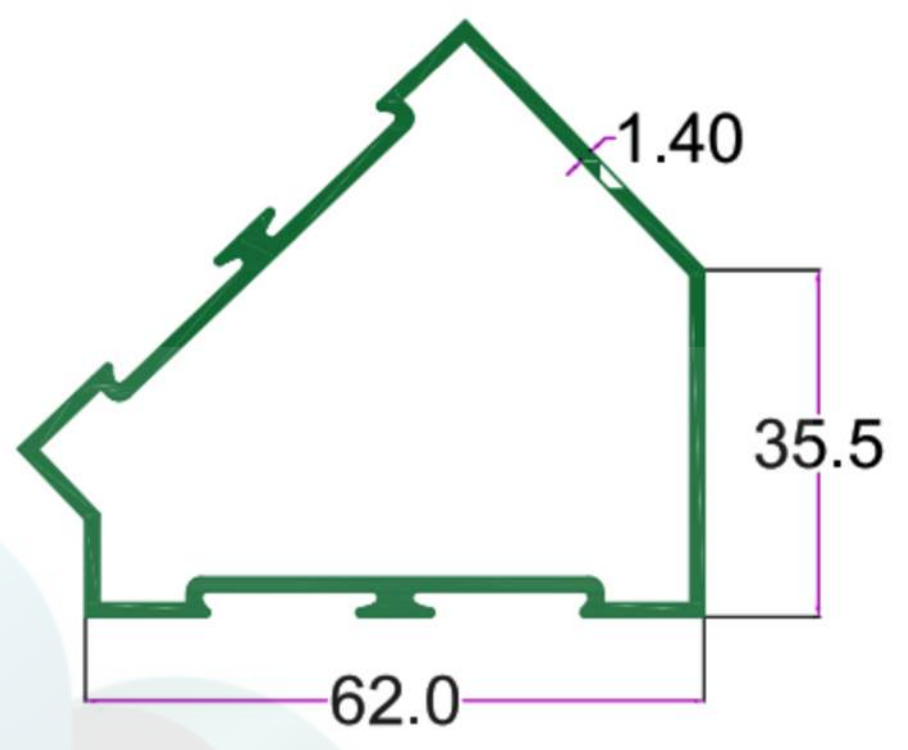

SEC.No. 1756
WT. 3.800 TO 5.00 KG/15'

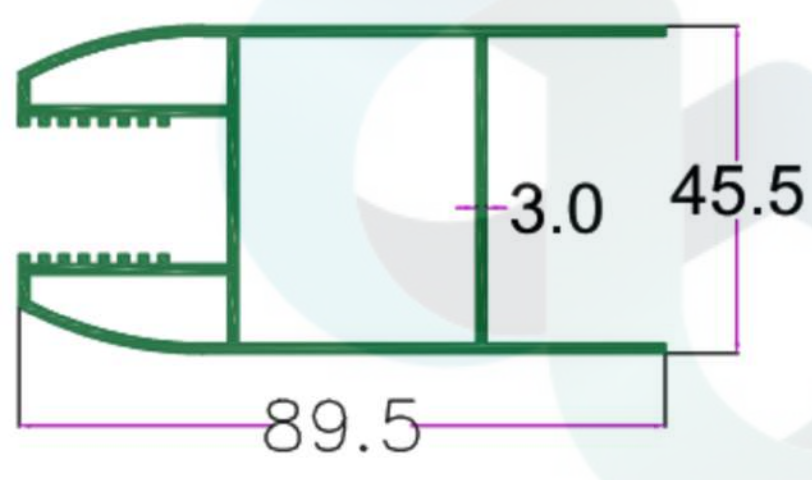

SEC.No. 1759
WT. 8.500 TO 9.500 KG/15'

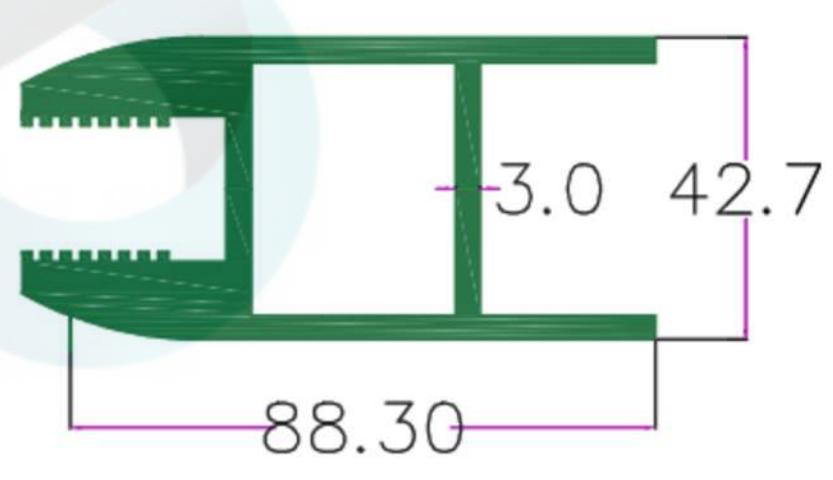

SEC.No. 1758
WT. 10.00 TO 11.00 KG/15'



SEC.No.-1754
WT. 0.615 TO 0.720 KG/12'

S.No.	Section No.	A IN mm.	B IN mm.	T IN mm.	Weight (KG/15')
1	3818	44.00	5.00	0.80	0.450-0.500
2	1754	44.00	5.00	1.00	0.610-0.700
3	1755	44.00	5.00	1.20	0.800-0.900

DOOR SECTION



INTELLIGENT
ALUMINIUM
itswallpanel.com

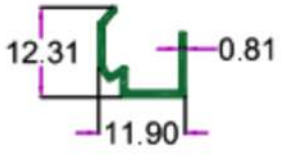

SEC. NO. 3995
WT. 0.500 TO 0.700 KG/I2'

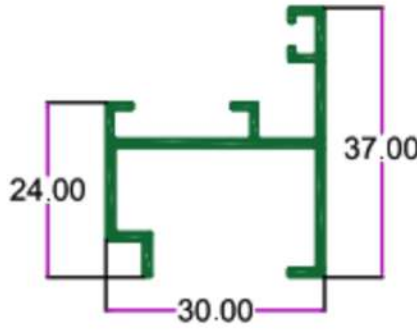

SEC. NO. 3994
WT. 1.300 TO 1.600 KG/I2'

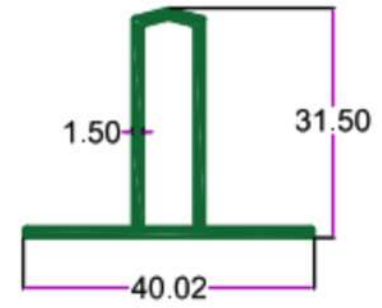

SEC. NO. 4017
WT. 1.500 TO 1.700 KG/I2'

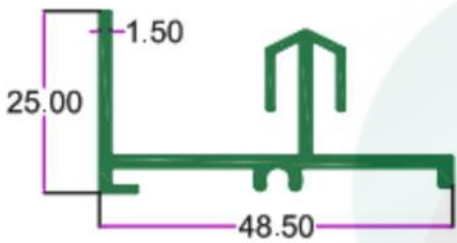

SEC. NO. 3993
WT. 1.750 TO 2.000 KG/I2'

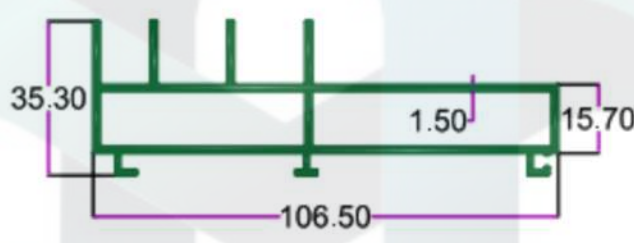

SEC. NO. 4027
WT. 4.900 TO 5.300 KG/I2'

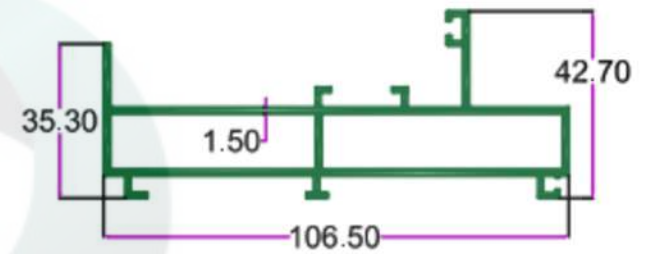

SEC. NO. 4025
WT. 4.800 TO 5.200 KG/I2'

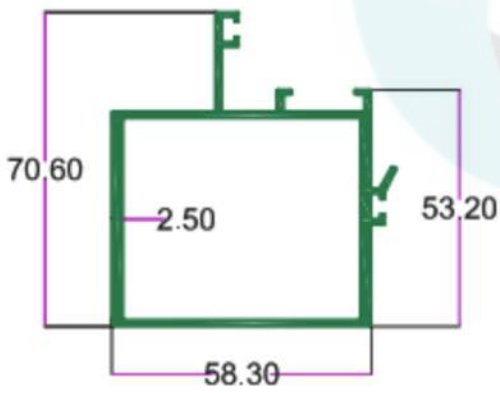

SEC. NO. 4026
WT. 4.700 TO 5.00 KG/I2'

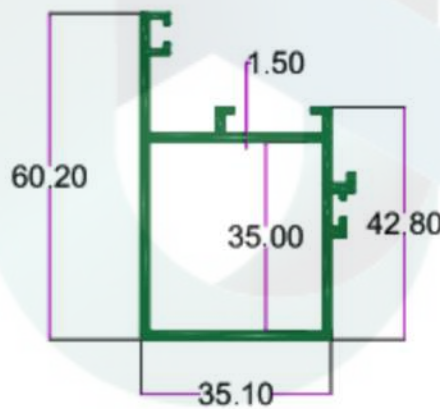

SEC. NO. 4028
WT. 2.800 TO 3.100 KG/I2'

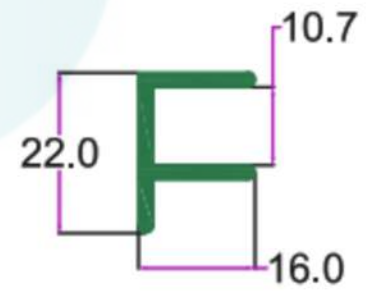

SEC. NO. 2842
WT. 0.850 TO 0.950 KG/I2'

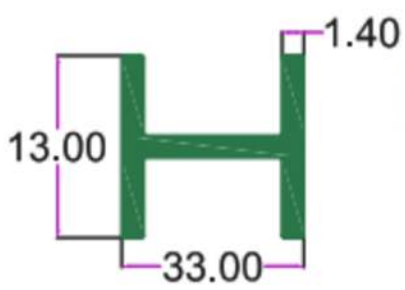

SEC. NO. 533
WT. 1.000 TO 1.200 KG/I2'



SEC. No. 3376
WT. 1.150 TO 1.450 KG/I2'

DOOR SECTION



INTELLIGENT
ALUMINIUM
itswallpanel.com

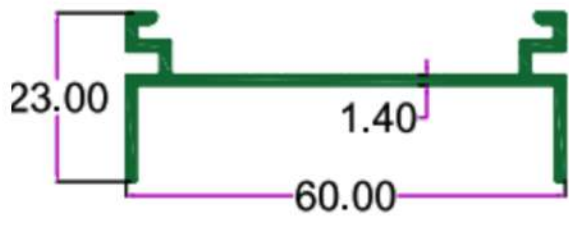

SEC. NO. 3888
WT. 1.600 TO 1.900 KG/12'

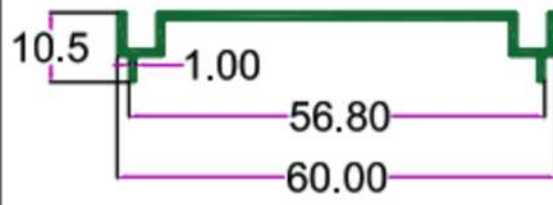

SEC. NO. 3891
WT. 0.890 TO 1.200 KG/12'

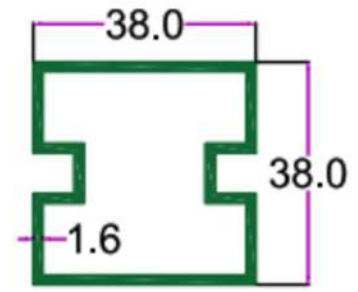

SEC. NO. 3136
WT. 2.745 TO 2.950 KG/12'

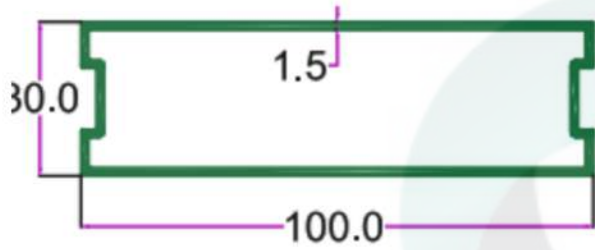

SEC. NO. 3601
WT. 3.700 TO 4.200 KG/12'

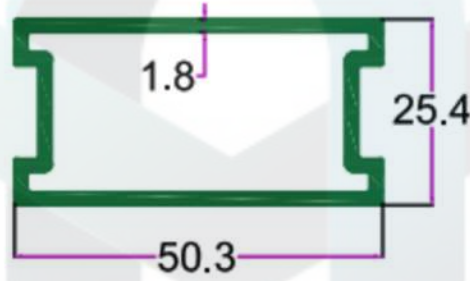

SEC. NO. 3602
WT. 2.600 TO 3.000 KG/12'

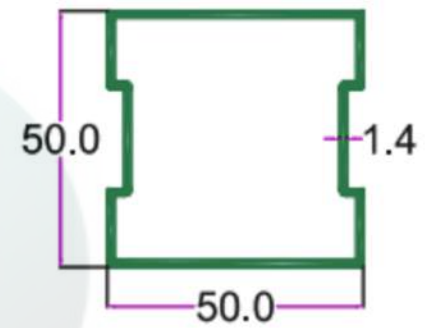

SEC. NO. 3603
WT. 2.700 TO 3.000 KG/12'

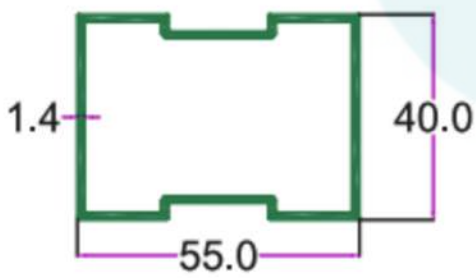

SEC. NO. 3604
WT. 2.600 TO 2.900 KG/12'

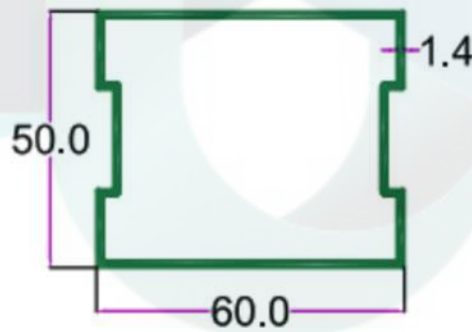

SEC. NO. 3608
WT. 3.000 TO 3.300 KG/12'

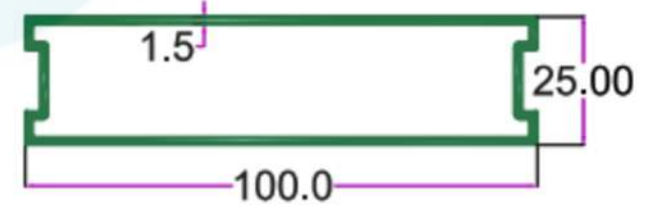

SEC. NO. 3607
WT. 3.600 TO 4.000 KG/12'

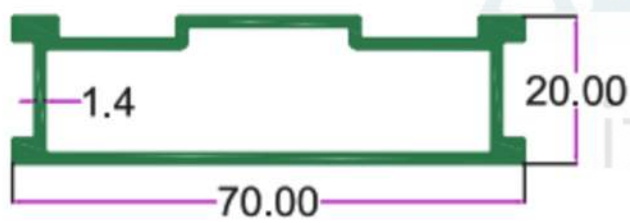

SEC. NO. 3606
WT. 2.700 TO 3.000 KG/12'

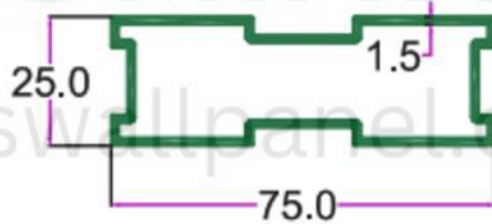

SEC. NO. 3605
WT. 3.000 TO 3.450 KG/12'

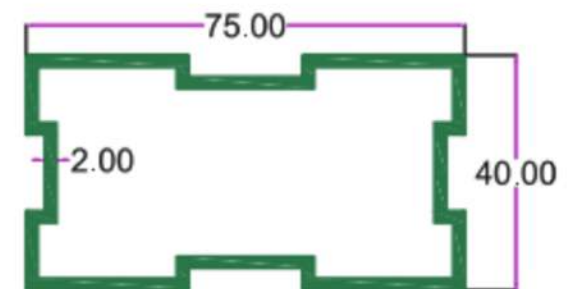

SEC. NO. 3830
WT. 4.90 TO 5.30 KG/12'

DOOR SECTION



INTELLIGENT
ALUMINIUM
itswallpanel.com

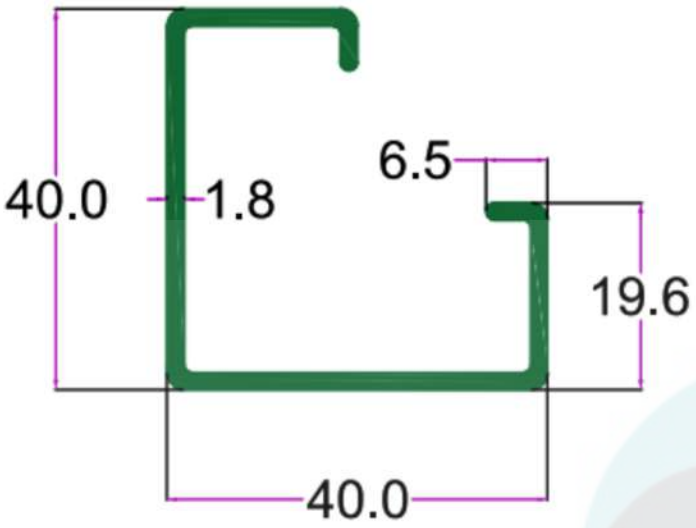

SEC.No. 2043
WT. 2.100 TO 2.300 KG/12'

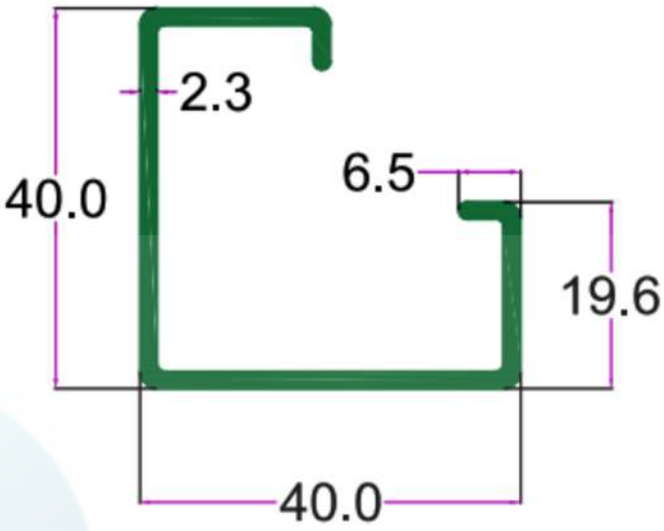

SEC.No. 2044
WT. 2.600 TO 2.800 KG/12'

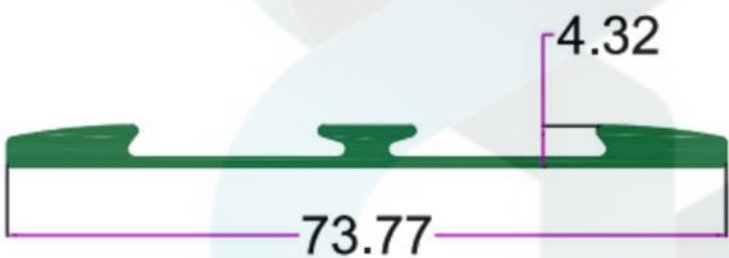

SEC.NO. 3317
WT. 2.000 TO 2.500 KG/12'

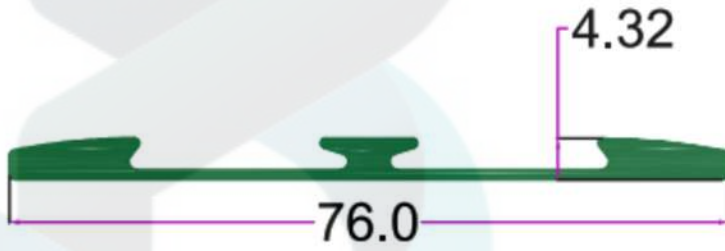

SEC.NO. 3318
WT. 2.200 TO 2.600 KG/12'

INTELLIGENT
ALUMINIUM
itswallpanel.com